

How To Read

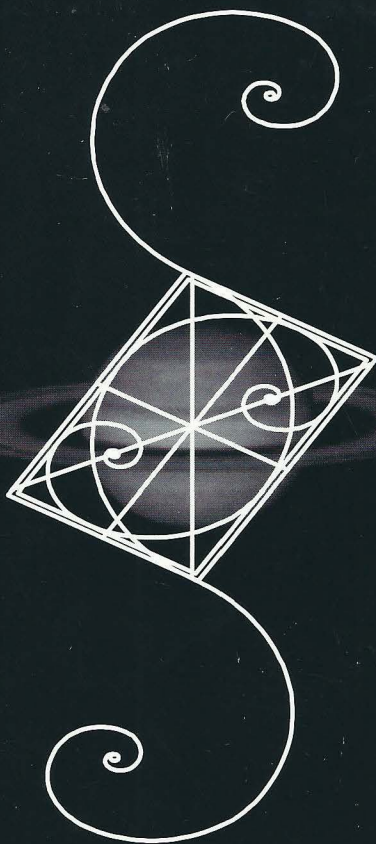

*After
more than
half a century
the silence is
broken*

His Writings

The Unauthorized Guide to Decoding Edward Leedskalnin's Works

ED.L.

by ED. M.

How To Read

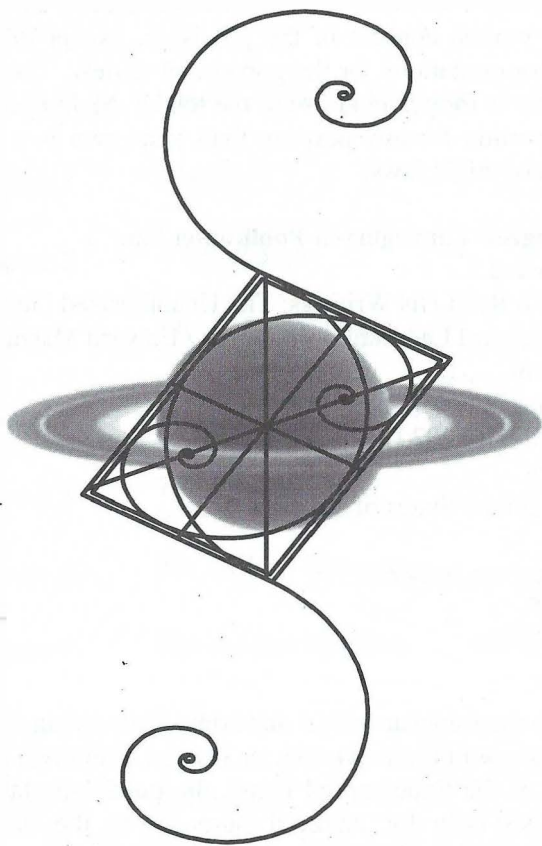

His Writings

The Unauthorized Guide to Decoding Edward Leedskalnin's Works

E D.L.

by ED. M.

How To Read His Writings: The Unauthorized Guide to Decoding Edward Leedskalnin's Works

Copyright August, 2000 by Passels Information Network

All rights reserved. This book may not be duplicated in anyway without the expressed written consent of the publisher, except in the form of brief excerpts or quotations for the purpose of review. The information contained herein is for personal use of the reader. Making copies of this book or any portion for any purpose than your own is a violation of United States copyright laws.

Library of Congress Cataloging-in-Publication Data

Marlinski, Edward J.

How To Read His Writings: The Unauthorized Guide to
Decoding Edward Leedskalnin's Works / Edward Marlinski - 1st ed.

p. cm.

Includes index.

ISBN 0-9701202-0-6

Printed in the United States of America

Passels Information Network
P.O. Box 1245
Lansdale Pa. 19446

Trademarks

Trademarked names appear within this book. Rather than list the names and entities that own the trademarks, or insert a trademark symbol with each mention of the trademarked name, the publisher states that it is using the names only for editorial purposes to the benefit of the trademark owner with no intention of infringing upon that trademark.

Limits of Liability and Disclaimer

The information and procedures contained in this book are based upon research and personal experiences of the author. The publisher and author are not responsible for any adverse effects or consequences resulting from the use of any suggestion or procedures discussed in this book.

Contents

<i>Message</i>	<i>xii</i>
<i>Preface</i>	<i>xiii</i>
<i>Introduction</i>	<i>How to Read His Writings</i>	<i>xiv</i>
<i>Chapter 1</i>	<i>Clueless</i>	<i>Page 1</i>
<i>Chapter 2</i>	<i>A Small Sign</i>	<i>Page 11</i>
<i>Chapter 3</i>	<i>The Clues and Symbols</i>	<i>Page 15</i>
<i>Chapter 4</i>	<i>The Path and the Thin Machine</i>	<i>Page 25</i>
<i>Chapter 5</i>	<i>The First Machine</i>	<i>Page 37</i>
<i>Chapter 6</i>	<i>The Golden Geometry</i>	<i>Page 49</i>
<i>Chapter 7</i>	<i>The Second Machine</i>	<i>Page 52</i>
<i>Chapter 8</i>	<i>Light</i>	<i>Page 66</i>
<i>Chapter 9</i>	<i>Silhouettes</i>	<i>Page 76</i>
<i>Appendix</i>	<i>Page 82</i>
<i>Index</i>	<i>Page 107</i>

This writing is lined up so **you can read it**. but don't go to the end now to find it, because you will run right over it and miss it.

So how should you start to read this book? You will need a few things, but the first item you will need, is a full set of Edward Leedskalnin's writings, printed in English. You can get a set of EDL's writings from his Coral Castle Park. Why do you need a set of his writings instead of downloading some third party copy from the Internet, or a copy from a friend? You will quickly find out, as we now start to learn how to read his work from his words and subtle clues.

Let's play around a bit with EDL's writings before getting serious. EDL should not mind, because he took a lot of time to write them in the way they are presented to you.

A special note to those of you who have already read his writings and found them to be lacking in good grammar, spelling, general context flow and the way he presented his knowledge of science. Go dust off your dictionaries, science books and star charts from where ever you put them last because you may find that you will need them all.

*To those of you who have never read his writings, don't fret, because the way in will be disclosed **BUT, before you continue** take a little time to browse through his writings at least once. You will then appreciate the clues he left behind that you missed.*

Both new and seasoned readers of EDL's writings will come to appreciate, that EDL anticipated that most individuals who suspected that there was a hidden message would just dive into his work without stopping to see the clues that he left for all to find. He was also counting on one other thing, which will reveal itself as you read on.

So, let's start by watching **Clueless**, our imaginary friend, as he follows the path many have taken in their futile attempts, for over half a century, to discover the entrance to Edward Leedskalnin's *Magnetic Current* booklet.

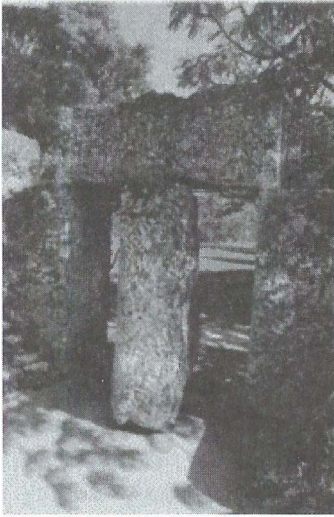

9-Ton Rotating Gate

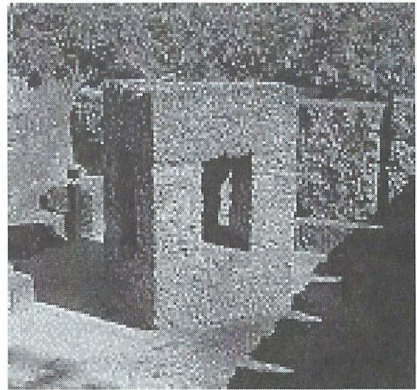
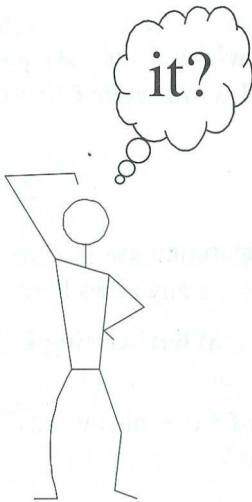
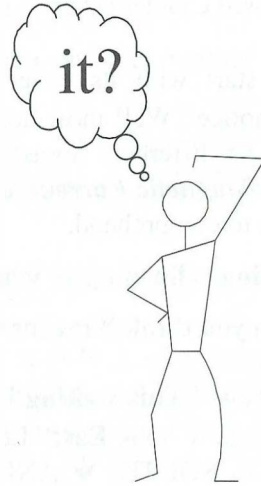

Barbecue

Photographs published by Coral Castle, Homestead, Florida

Author's Message On What It's All About

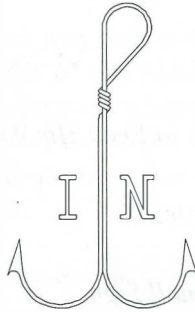

*Some think that fishing is senseless waste of time
that's why they use a net instead of a hook and line.*

ED. M.

This book will show you how to break into Edward Leedskalnin's writings, starting with his *Magnetic Current* booklet, published in August 1945.

Some who read what follows, will be shocked and outraged that both this book and EDL's writings were put to print. Some will see and understand what it is all about, while others will be amused or think that over fifty years ago, Edward Leedskalnin fabricated an elaborate hoax. Whatever your viewpoint, you have the same opportunity to research the subject in your own way, to prove it to yourself.

Preface

All of mankind follows the same cycle of life. We are first born, live out our lives and then pass on.

When we are born, we all start the same, with no knowledge or concept of what life is all about. We have no language, science or religion. We have no concept of patriotism, hate or prejudice. We have no awareness of God or country. We acquire these first pieces of knowledge, be it right or wrong, from what we are taught. These are the words whispered in our ears, the things shown to us, and the words written down by our predecessors for us to read, learn, and use. The second source of knowledge is what we learn on our own. The more roles we play out in our life, the more understanding and knowledge we attain. If we believe this knowledge to be of importance, we then, in turn, pass it on for the next generation of mankind to use. That is the general basis of how mankind's total acquired knowledge developed over time. It started when the first father passed on his knowledge to not just one, but to both that he called son.

Unfortunately, the most ancient whispered and written words were altered over time. War, poor phrasing and multiple translations have concealed their true meaning from us today. Some of this ancient knowledge was purposely forgotten as more advanced knowledge replaced the old ways. Some knowledge, however, was purposely destroyed because it was a detriment to the existence of mankind.

Now what would you do if you possessed knowledge of a natural power that the world had forgotten, or chose to forget? Would you give it to a world during or just after the turmoil of a world war? How would you then pass it on to the next generations to come, and how would you pre-select into whose hands it would be placed?

Reader, ponder these words before you move on. They are not riddles, but a mere glimpse of the truth.

Is there a cycle where nothing becomes something and returns back to nothing again, or where something can become nothing and return to something once more?

Before the dawn was there not the darkness that shadowed the light?
Before the dusk was there not the light that illuminated the darkness?

Their wondrous temples and timeless gates of stone remain, but now in ruin and neglect.
Have you ever asked yourself why mankind did not keep them in repair?

Before the knowledge was there not the ignorance that hindered the truth?
Before the ignorance was there not the truth that destroyed the knowledge?

Did these architects leave because their task was done, or was man's ignorance filled with their knowledge to rival them and block their passage of return?

True knowledge can unveil unspeakable power, because the impossible can become just a mere barrier that can be shattered by the truth. Use restraint and practice your knowledge in a humble way. Use it wise and true, because in a twinkle of an eye

So where will Clueless start to read EDL's *Magnetic Current* booklet?

Will he start with its cover or its second page, which contains a copyright notice? Well most don't even pause to look at these pages and Clueless is no different. So as we watch he will start where most start to read EDL's *Magnetic Current*, at the very first and most troublesome line of his work to comprehend.

"This writing is lined up so when you read it you look East," ⁽¹⁾

So what do you think it means Clueless?

Let's see now. "This writing is lined up so. ." Hmm . . . Lined up so. . .
Hmm . . . 'read it' 'look East' Let's see. Hmm WOW! Up is up ↑
and so . . . IS SOUTH! ↓ AND EAST IS THAT WAY → . . . LOOK
EVERYBODY IT'S NORTH AND SOUTH. WOW THERE IS A
WHOLE PILE OF NORTH AND SOUTH AND IT WORDS IN HERE
SO I'M GOING TO GO LOOK AT THEM NOW. → → → → →

Well, as we wait for our friend to get back, and since we are here, let's take a closer look at the opening line of EDL's *Magnetic Current* since we may need it later on.

"This writing is lined up so when you read it you look East,"

Let's start by first breaking this first line apart and ask ourselves as many questions about it as possible, to see if there are any clues here.

"This writing . ." Let's first ask ourselves. What writing is he talking about? Is it:

- This whole *Magnetic Current* writing of 8,000 plus words?
- This first line of text we are presently at?
- A Phrase?

⁽¹⁾ Leedskalnin, Edward: *Magnetic Current*, The Franklin Press Inc., Miami, FL, August 1945, pp. 3.

- A Word?
- A letter?
- A punctuation mark?
- Or is he talking about some other text or other writing that he or someone else authored all together?

Should we read the phrase "**This writing . . .**" as the words **THIS** and **WRITING**, or could it be broken down further as "**T HIS WRITING**", or "**THIS WRIT IN G**" . . . etc.?

And, the next phrase "**. . . is lined up so . . .**"

What kind of line is he talking about and how is it lined up so?

Does he mean a direction ($\uparrow \downarrow \rightarrow \leftarrow \swarrow \searrow \nearrow \nwarrow$), or a text symbol that is like a line such as a **hyphen -** or an **underscore _** ? Or do we have to draw a line or crease the paper in some strange origami way, to get some text or symbol to line up so?

Clueless you are back! Any luck? No?

Too bad, we were just going to look at "**. . when you read it you . .**"

WOW! "YOU" I SAW A LOT OF YOU WORDS AND U WORDS IN HERE SO LET'S GO LOOK AT THEM NOW. LET'S GO $\rightarrow \rightarrow \rightarrow \rightarrow$

Good Bye Clueless.

Now where were we? Oh yes, "**. . so when you read it you look East,**"

What **YOU** is he referring to? Is Clueless finally right? Is **YOU** the same as **U**, and what is the **IT**? Is EDL referring to the word **it**, or is **it** a thing or some symbol?

Does look **East** mean look to the right or East of North? Should we be in the West to look East, or should we take the word East and break it down to read **E as T**?

And let's not overlook that this first line ends with a comma. So let's ask ourselves if we should look at it as **East**?

Let's stop here for a moment for a little insight about EDL.

Your First and Most Important Lesson to Remember . .

Let's pretend we are now living at the time EDL was alive. We drive up to his Rock Gate Park, get out of our car and as we walk along stone walls that are too high to see over, we are greeted by a closed gate, his three-ton gate at the West end of his property. We look around and see a sign next to a small hanging bell that instructs us to ring it twice. Now, if you rang it only once or more than twice, he never came to open the gate. If you rang it twice, waited patiently and he was not busy, he would come to let you in, that is, if you paid his admission fee first. Remember, He was a man of business.

So what does this have to do with this first line, **"This writing is lined up so."**?

EDL, as you can perceive, was very specific in his instructions. So let us keep this fact in the back of our mind as we continue.

WELL I'M BACK. NO LUCK, DARN IT!

Too bad Clueless we were just talking about . . .

I HEARD YOU. RING BELL TWICE. THAT'S TWO. . . WOW I SEE IT NOW **"This writing is lined up so."** UP AND DOWN MUST BE TOP TO BOTTOM↓ OR IS IT BOTTOM TO TOP ↑? WHICH WAY DO I GO? GOT A LOT OF POSSIBILITIES HERE. . .SEE YOU LATER. BYE . . . →

Well now that we are finally alone, let's start to get serious now about looking for clues that will lead us to the entrance of **"This writing . . ."**. Since we are here on page 3 of EDL's *Magnetic Current* booklet, let's take a closer look at it.

How close should we look?

Use a magnifying glass. **Go get one. Do you see the line?** It's in the insert on the next page.

MAGNETIC CURRENT

This writing is lined up so when you read it you look East, and all the description you will read about magnetic current, it will be just as good for your electricity.

Following is the result of . . .

Insert from - Leedskalnin, Edward: Magnetic Current, The Franklin Press Inc., Miami, FL., August 1945, pp. 3.

Now, let us recall EDL's instruction to **Ring** the bell twice.

Let's first look at the two R's in the word CURRENT located in the top line on page 3 of EDL's *Magnetic Current* booklet.

MAGNETIC CURRENT

Do you see that these TWO "R's" are slightly different?

MAGNETIC CURRENT looks like MAGNETIC CUPRENT with a line drawn up to make the P look like an R.

So is this really a clue, or is it a typesetter's way of getting around the lack of having all the same font in his capital R box to pick from?

Your Possible Clue No. 1:

For now, let's put this C U P R E N T in our possible list of clues and continue browsing through EDL's *Magnetic Current* writing looking only for clues now.

Clueless! You're back, and you have a grin on your face.

YES! I FOUND THE ENTRANCE. . . . WELL I THINK I MAY HAVE?

That's great Clueless, but what do you mean you think you may have?

WELL ALL RIGHT I'LL TELL YOU.

YOU SEE I PEEKED IN AND HE TOLD ME TO GO AWAY.

He did?

YES. HE DID!

Tell us about it Clueless.

WELL . . IF YA PROMISE NOT TO TELL . . . THIS IS WHAT HAPPENED . . .

I WAS LOOKING UP AND DOWN AND DOWN AND UP AND ALL AROUND. THEN IT DAWNED ON ME, THAT I NEEDED TO KEEP IN MIND WHERE EAST WAS IN RELATION TO WHERE I WAS, AND THAT I NEEDED TO START AT THE START. SO I FOUND THEM, THE WORDS **start**, BUT THEY DIDN'T GET ME ANYWHERE. SO I WENT BACK TO EAST AN. . .

Slow down Clueless, just tell us what you did.

OK. . . I DEDUCED THAT EAST WAS "E" "AS" the place to s"t"art. SO I SAID TO MYSELF, WHERE IS UP SO E? SO DOWN I WENT TO THE BOTTOM OF PAGE 19 AND POSITIONED MYSELF IN THE BOTTOM LEFT CORNER AND FOUND THE WORD **particle**.

SO I SAID TO MYSELF ONCE AGAIN. SELF, THAT'S WHAT I CALLS MYSELF. SELF, I ASKED, WHICH WAY IS EAST FROM WHERE I AM?

WELL IT WAS THIS WAY → I SAID TO MYSELF.

SO IT WAS THEN THAT I SAW THE **particle** AND THE **E** IN IT **particle** ↔ **e**.

THEN I WENT UP ↗ TO THE TOP RIGHT SIDE OF PAGE 19 AND FOUND THE WORD **electricity** AND REALIZED **IT WAS SPELLED WRONG**.

INSTEAD OF **city** IT WAS SPELLED **ctiy**.

SO IT HAD TO MEAN SOMETHING. IT WAS THEN, I REMEMBERED WHEN YOU READ **IT**, YOU LOOK EAST→. SO

INSTEAD OF GOING UP LEFT EAST I WENT RIGHT EAST AND GRABBED ONTO THE LETTER **y** in **ctiy** ↔ **y**.

THEN I WENT DOWN SO ↓ AND FOUND THE WORD **each**. WITH MY BACK AGAINST THE RIGHT HAND WALL OF THE MARGIN AND THE BOTTOM OF THE PAGE I LOOKED EAST ← AND GRABBED THE LETTER **e** ↔ **each**.

THEN I WENT UP ↖ AND FOUND THE WORD **functions** LOOKED EAST AND FOUND THE LETTER **functions** ↔ **s**.

SO I REALIZED I FOUND **e y e s** → **EYES** BY GOING (→ **e**) (↗ **y**) (↓ **e**) (↖ **s**)

THEN I CONTINUED WITH MY TACTICS AND WENT TO PAGE 18 BUT THERE WAS NO WORD ON THE BOTTOM LEFT SIDE TO BE FOUND.

SO I WENT BACK ↗ → TO THE → **p** in **particle** ON THE LOWER LEFT CORNER OF PAGE 19. I COULDN'T GO DOWN ↓ THERE WAS NO WHERE TO GO. SO I THEN WENT ↖ ACROSS AND UP ↑ THE MARGIN BETWEEN PAGE 18 AND 19 AND FOUND THE WORD **their**, LOOKED EAST AND FOUND **their** ↔ **r**.

I THEN WENT BACK ACROSS THE MARGIN BETWEEN PAGE 18 AND 19 AND SAW THE MISSPELLED **electricity** AGAIN.

IT WAS THEN I SAW IT WAS LINED UP IT. SO I GRABBED ANOTHER **y**.

SINCE I ALREADY WENT THROUGH PAGE 18, I THEN WENT DOWN ↙ TO THE BOTTOM LEFT CORNER OF PAGE 17 AND FOUND **ing** AND REALIZED I SPELLED **p r y i n g**

prying eyes.

THEN I CONTINUED UP RIGHT ↗ LOOKED EAST AND FOUND **filings** ↔ **s**. THEN DOWN ↓ TO **away** AND THEN UP ↖ AND ACROSS TO **go**.

SO WHEN I PUT IT TOGETHER, WHAT DID I FIND?

go away sprying eyes!

WHAT KIND OF MESSAGE IS THAT ANYWAY, HUH?

Well we don't know Clueless, but since we found a correlation between P and R with a possible line like a hyphen between them as in the word current, your line of text might spell out the phrase:

Go away spying eyes!

YOU FOUND THE HYPHENATED WORD CUR-RENT?

MAN. I'VE SEEN SO MANY HYPHENATED WORDS YOU COULD . . . GOT TO GO . . SEE YA → → → → → → → → → → → → → → →

Bye Clueless. See you later.

So what do you think?

Do you think Clueless made a real discovery? Did he do anything wrong?

Many times the author of a hidden text would leave false messages or trails to throw you off the path, which is what Clueless may have found. Or, maybe this is a true **Stop** command purposely left by EDL. **But . . in any event**, Clueless did something wrong. **He didn't stick to his plan**. At the end when he saw the words **go** and **away** he grabbed on to the word that caught his eye, as well as the **ing**, that fit instead of looking for the individual letters of the word sequence he was trying to discover. *Remember this if you ever would retrace the steps Clueless took.*

Let's now look at the copyright notice on page 2 of EDL's work. His copyright notice is reproduced below. **It looks quite normal or does it?**

**Copyright, August, 1945
By Edward Leedskalnin**

Insert from - Leedskalnin, Edward: Magnetic Current, The Franklin Press Inc., Miami, FL., August 1945, pp. 2.

Get your magnifying glass and look at it again. Look at the **A** in August. Do you see that it has a line above it? Does EDL mean copy this right **A**? But how about EDL's ". . when you (U) read it you (U) look East,"? Does he mean that the **G** in AUGUST is it? How about the hidden **a** that is in 1945? If 1= a; 9= i; 4= d; 5= e, 1945 could spell out **a i d e**.

Also notice that the legs of this lined up **A** in the word August are centered about the **L** in EDL's name. If they were extended down about that letter **L** they might just form the sides of a pyramid.

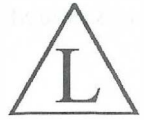

Well let's remember this and continue back at the top of page 3 of EDL's *Magnetic Current* and look again at the **A** in *MAGNETIC C U P R E N T*. That **A** has the same line, but also note that the two E's are missing an up bar, like a rod, **in** its center leg.

Although it may not mean anything, we will remember these lines as we move on to the other possible clues to be found on page 3 of EDL's *Magnetic Current*.

How about EDL's choice of starting word(s) for his first 6 paragraphs? They yield the word sequence:

This .. Following .. First I .. Now .. In .. The ..

How about the first word string looking down the left margin of page 3:
This .. and .. will .. Following?

How about the cross corner string that follows the shape of a Z:
This .. East .. as .. individual?

And, if you are looking for something to line up, how about the word **MAGNET** on the top of his page 3? If you would connect the two T's of the title line on their centers like this $\overline{\text{TT}}$, then those of you that like to fold paper in an origami way would then read his first line as "This writing is lined up - you look East,".

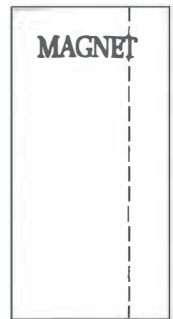
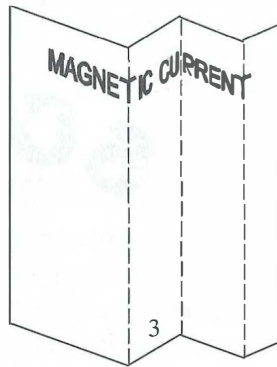

Also, if you really like to fold paper and can't resist how about the line that is up O on page 11 of his *Magnetic Current* booklet? If you read along the crease you made you will then see from the folded up words on

page 12 and the corresponding words on page 13, what he used is quite old indeed.

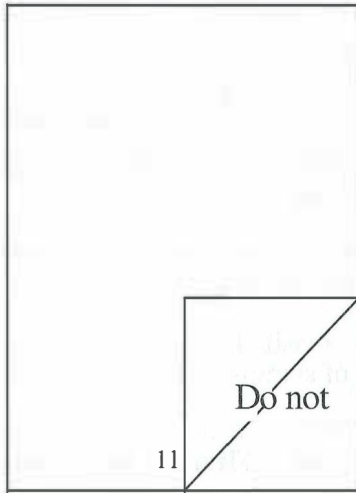

The more you look at his writings to find a way in, the more possibilities you will find. It's almost like trying to find one star in the night sky or one kernel of corn in a bowl of vegetable soup. Or is it **so up**?

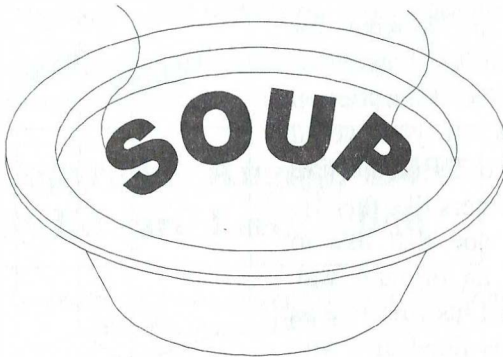



(Photograph of Edward Leedskalnin published by Coral Castle, Homestead, Florida)

If you ever saw a picture of EDL, you would usually see him with a small sign.

It is a small insignificant sign, for it only contains the three letters of his name. It seems quite innocent and normal does it not? Something you would just normally overlook. The odd thing, however, is that when you see enough pictures of EDL you will usually see his sign. So there must be something more to it, wouldn't you think? Also, if you ever stopped to look at his sign, you would notice one more thing. There was not one sign but in fact two.

One was **EDL** the other was **ED. L.** where he added the periods, two.

Now let's look at these signs a little closer, to see if there may be something here. Remember, it is claimed, that this quiet man of small stature lifted and moved incredibly large heavy stones, all by himself. So let's not overlook anything to find out how he may have done it.

If you look closely at these two, three letter signs, you will start to notice a possible subtle message in both. In fact, each may have two messages, for a total of four, which we may find.

Let's look at the sign without the periods first **EDL**

Let's look at these three letters, E D L, in Morse code.

E	D	L		See the symmetry? Is it just a coincidence?		
·	·-·	·-·-·	E D L	L E D	E D E D	L L
			· -· ·-·	·-· · -·	· -· · -·	·-· ·-·

The key here may be the letter E, which in Morse code slang means **echo**. In other words, if you were a Morse code operator and heard the E you would respond. We will not respond as a Morse code operator would. We will, however, heed the little bell that would echo as you rang it twice to walk through his gate at his Rock Gate Park.

Let's now echo or reverse EDL or ·-·-·-· as ·-·-·-·-· and see what we get.

·	·-·	·-·-·	Let's echo	·-·	·-·-·	·-·-·-·-·	Let's echo	·-·	·-·-·	·-·-·-·-·
			it				it again			
E	D	L		N	O	W		A	S	D

If asd would read sad we would get **EDL NOW SAD**. The question is why would he be sad, or is there another interpretation here yet to be found, since we did in fact move the last three letters around?

Instead, let's now mirror EDL or ·-·-·-· as ·-·-·-·-· and string it together with another EDL or ·-·-·-· and see what we get.

·-·	·-·	·-·	·-·	·-·	·-·-·	·-·	·-·
I	N	I	T	E	A	S	T

Well it does sound familiar since he tells us in his *Magnetic Current* booklet **to look East**. It entices you to try more combinations doesn't it?

So let's now reverse ·-·-·-·-· again as ·-·-·-·-· and string it together with ·-·-·-· and see what we get.

·-·	·	·-·-·	·-·-·	·-·	·-·
M	E	O	L	D	R

Is this all a simple coincidence that is being expanded on incorrectly? Are we really looking for something that really isn't there? Or maybe there is more to it than we now just see? It's an important question to ask yourself now, because EDL might just be fishing. This may be simply some bait to lure you in for a closer look. What do you think?

For now, let's look at another possible interpretation of his sign that could be a statement of sorts when we use the complete name he was known by. Let's string the letters of his name about the three that we find in his sign. They are shown in white on the black background below.

W	A	E	D	N	I
D	R	E	S	L	N
E	D	L	K	A	

Not Ed's War?

Why would we get such a statement, **Not Ed's War?** How could one individual be accused of starting a world war, or did he play out a part in it that we do not know? Let's face it, there were a lot of people at the end of the war who were suspicious of anyone not born in this country. What do you think they might have done to poor old EDL if they would suspect that his little sign, or something else that he wrote, could be in some type of code? Was he concerned that someone, like us, would see this innocent sign and possibly interpret it incorrectly? There are a lot of questions asked here, and you would agree that there is no basis for them. It may be just pure speculation, and may not mean anything at all. So what do you think? It's an important question to ask yourself again, before you read on.

So let's put this all aside for now and view it as just pure coincidence and move on to his other sign.

The sign

ED. L.

 where he added the periods, two.

It has but only one message for now, that is if we want to echo it of course.

. L . DEED . L .

Who knows, maybe it will echo out a ring later on?

Maybe once we find his deed we will have claim to his writings and how he did the impossible by moving all those large heavy stones alone?

Maybe, however, his small sign hides a small hook instead, with the possibility of discovering his knowledge, or hidden fortune, as the bait?

What do you think reader?

Should we continue on and get lured in for a closer look?

Before we break into his writings, we will need to make two simple assumptions.

The first is that EDL did leave a hidden message of importance for us to find. Second a logical path of clues, or markers, for us to follow to get to his hidden message. If you continue on where this little book leaves off, you will find, that both of these assumptions are more than true, since EDL left not just one, but multiple messages for us to find. Once you have the proper tools and learn how to see his clues and symbols, you will find that each of his messages, or levels of difficulty, are tailored to the background and knowledge of the reader. Science, religion, the stars, mathematics, sex, humor . . . they are all in his writings. To find them, however, besides having the knowledge, patience and the right tools, you will need your wit, because that is what the game is all about. It is your wit against his, if you want to claim the prize.

This little book will not only reveal the key symbols he left for you to find, it will also show you how to use them, with actual examples. From there you can continue on with confidence **that it is his instructions that you will be following** and not just arbitrary words put in to fill this little book.

So let's start once again as children, as we now learn his language of symbols before we move on to **his encoding machines**. Let us start by taking a step back, by looking at all his writings on a global scale and heed his clues, so we will not fall into the many traps EDL laid for us to get snared into as our friend Clueless did. Some will be explained now, and some later on. There are quite a few of them and most are not needed to learn how to break into his writings. While we are at it, we will cover as much as time will permit, since time is precious and we have a lot to do.

Let's start by first taking a look at the cover of EDL's *Magnetic Current* booklet.

You will first notice that its cover has a double lined border. We need to realize that EDL left this as a symbol for us to interpret and use, as with the fact that his pamphlet entitled; "*Mineral, Vegetable and Animal Life*" bears the same border symbolism. Since we assumed above that there is a hidden message contained in his writings, we will now associate this border as his warning to read carefully between the lines. Also, if you recall from your first lesson, we should expect that EDL had another symbolic meaning for this border. Since we would have to speculate about its meaning, we will wait for now, but you will see it pop up, like a tent, as a circle in a circle as you read on below.

Now put both EDL's *Magnetic Current* booklet and his pamphlet entitled, "*Mineral, Vegetable and Animal Life*" on the table in front of you so we can compare them.

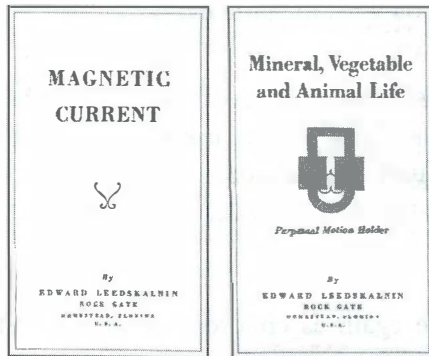

Covers from Edward Leedskalnin's booklets published by The Franklin Press Inc., Miami, Florida (1945)

Lets first compare the borders on these two covers to see if they are the same in height and width. As stated before, a copy of these booklets would be useless here unless they were copied on the same copy machine at the same time. So again, you are urged to get an original set of EDL's writings. Well, have you compared the two borders? What did you find? Do you agree that the border on EDL's *Magnetic Current* booklet is slightly taller than the one found on his pamphlet entitled, "*Mineral,*

Vegetable and Animal Life"? Second, we should also agree that the border on his pamphlet entitled, "*Mineral, Vegetable and Animal Life*" is wider than the one found on his *Magnetic Current* booklet. In fact, if you were able to lay one on top of the other on a light table, you would see that they would lay into each other. Oh yes, it is not suggested that you look East into the rising sun to do this, at least not yet. Use a light table instead, the sun can really mess up your eyes if you look directly at it. -- So what was this all about? The borders of these two works are almost alike, but not quite the same, just like twins. Now here is an odd question for you to think about now, which will be answered below. Did these twins have the same father, or were there two? Let's not over look their geometry of course. What does geometry have to do with his writings? If EDL followed the ways of old, wouldn't you think he would have used some Golden Geometry?

Let's now examine and compare the two main titles of both. Let's first look at the font used. Of course we will only be able to compare the capital letters, but let's do it now. Well how did you do? That was easy. There are only two that are the same on both. Notice that the left leg of these upper case M's are thin and their right legs are thick, and the two lines in the middle, that take on the shape of a V, follow the reverse. How odd, it makes one wonder why he did that? It almost looks like a check mark or a square root sign doesn't it. Or maybe, if it were sitting over a reflective surface it would look like IXI. Like an absolute |X| in math, or possibly X marks the spot as when his two A's line up tip to tip. Well, let's not waste our time on this now, since we have a lot to cover here.

The only thing else of note on these cover pages besides the two symbols, or pictures as he called them, and the words "Perpetual Motion Holder" on one, is the font he chose for the letter γ in the word By. Looks kind of like a Greek symbol doesn't it? Also, the center of his Perpetual Motion Holder picture looks almost like an I with the bottom that looks a little like a crescent moon, but with something that looks like a Greek ω in it. Lastly, since we already looked at the title of his *Magnetic Current* work, let's look at the title of its twin. There are four uppercase and twenty-five lower case letters and of course one comma. Four lower case

a's with the one capital A for five. One lower case b, one d, five e's, one f, one . . well lets just put them in a table and line them up so:

a a a A a	5
b	1
d	1
e e e e e	5
f	1
g	1
i i i	3
l l l L	4
Mm	2
n n n	3
r	1
t	1
V	1

Twenty-nine letters in all. Four uppercase, twenty-five lower and sixteen unique, and let us not forget the comma of course. Does it mean anything? Well right now nothing at all, unless you would want to read it as *C g film n r tv*. It may come in handy later on. At least there isn't a CC here. One could get quite suspicious if you would see **mc²**, wouldn't you?

Well, let's start to get into the juicy stuff now, by taking heed to his clue you will find at the end of Edward Leedskalnin's pamphlet which contains the topics, *Magnetic Base* and *Sound Base*, published by Coral Castle, Homestead, Florida.

"The above reading, The Magnetic Current, the Mineral, Vegetable and Animal Life and the Advertisement they all go together."

EDWARD LEEDSKALNIN.

5-20-46

The words "The table" "IN." and the letter "g" are highlighted here because we will use one below and the rest later on in this little book.

Also, let's not overlook the double lines that border his advertisement and what you get when you connect the two contained U's and read to the right.

MAGNETIC CURRENT

Researchers, experimenters and other people read about Magnetic Current, then you will know what it is, how it is made, what makes it, and the way it runs in the wire. Then you will know what the North and South pole individual magnets can do, and then you will know what electricity is. Send a Dollar Bill by return mail and you will receive an eight thousand word booklet postpaid, and in addition you will get a folder describing mineral, vegetable and animal life, and a drawing of perpetual motion holder, and another folder with several interesting subjects: Address to:

BOX HOLDER, ROUTE 1, BOX 196
HOMESTEAD, FLORIDA.

Insert Published by Coral Castle, Homestead, Florida

And don't overlook the Greek symbols Γ , a θ and a turned Ω that are disguised like a lower case "r", "e" and "a" which you will find in his pamphlet that contain the topics, *Magnetic Base* and *Sound Base*. So much Greek! Well it all looks like Greek if you ever tried to read his writings.

They are lost. Those
never come back (as)
in the ionosphere
of waves. Magnets
writings show.

Next, we should realize that his *Magnetic Current* booklet ends on page 19 and the only other writing supplied that contains pages at or above 19, is his little book.

↑ "ME ERY OK" ↑ Well he does look kind of eerie doesn't he? Oh yes, don't overlook the word KEY. Isn't it strange that he threw his little book in the pile? It really doesn't fit the rest. At least, you can kind of read it, and of course it was nice of EDL to leave a blank sheet next to each page so we could add our comments if we wished to. Let's look first, at page 19 of his little book. See if you can follow up the page . . . *higher . . . more . . . better . . . by* and notice it, but look hard, because you might miss it and read right over it, which will stop you from walking, instead of running later on.

Next, look at the back of his little book.

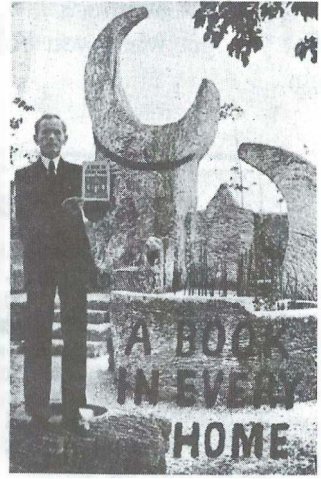

Leedskalnin, Edward: *A Book In Every Home*: Privately published by Edward Leedskalnin 1936



Photograph Insert:
Leedskalnin, Edward: *A Book In Every Home*: Privately published by Edward Leedskalnin 1936

See the table in the bottom picture? It's his Florida table, with the pool of water in it. It almost looks like an arrowhead or a mathematical notation that is, if it was pointing up, which here it is not, or is it? Of course EDL is sitting in his EZ chair, or is it a W like a Greek ω ? So much Greek! Well, look past the table now, towards the background of that picture. See his round seat shaped like a pilgrim's hat. It's the stone work he named as the *camera stand*. See how it just pops up out of the ground. Granted it's not rectangular like his border, but we are looking for his vague clues as symbols now. You would have to agree it would look like circle in a

circle, or an O in an O, if you would look at it from above. Speaking about looking from above, maybe it would be better to say Oh instead of O?

Well, now look at the next picture above the last shown on page 20 of this little book. You will find EDL standing in the center foreground. To his right, not ours, is the same camera stand. Now move up into his little book looking to your ← left, his right ←, as we left off. Confusing isn't it?

The next page on the left that has anything on it, is a picture of EDL demonstrating his electric generator.

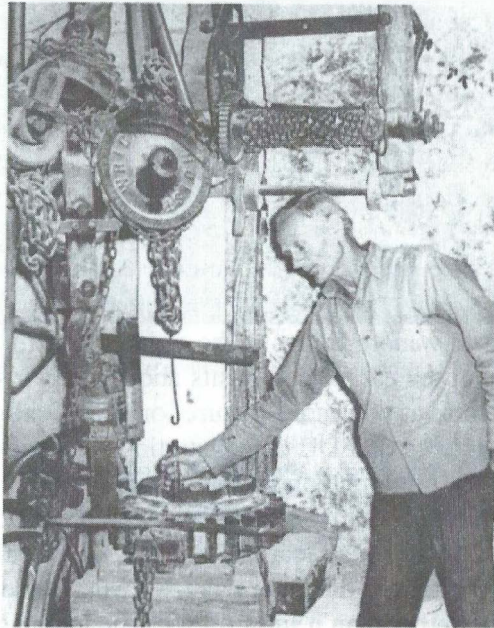

Photograph Insert:

Leedskalnin, Edward: A Book In Every Home: Privately published by Edward Leedskalnin 1936

Do you see anything strange about this picture? Look at it carefully and ask yourself the following:

1. Why in the world is a small thin wire, shaped like an elongated **J**, connected like a thread at the end of a large heavy thick chain hoist doing there?
2. Why are the **J** wire and chain not hanging straight down?
3. Why is the shadow cast by EDL not at the same angle as that cast by the hub on the chain hoist, and what in the world is that ball, see its shadow, doing on the hub of the hoist?

The **J** wire is first a warning that the temperament of language needs to be heeded, since, in some languages, such as ancient Latin, an **I** can be pronounced as a **J**. These letters, **I** and **J**, are also used as symbols in mathematics, if you would care to check. You will also find embossed on the face of EDL's hoist an **I** lined up **SO**. The ball and its wrong angled shadow could possibly represent a gnomon. That little vane you would find on a sundial that is used to cast a shadow onto a line or number to tell the time. So, do we stop here to speculate the meaning of all this now? Well, time is precious and we haven't gotten started yet.

There is more of course, but you should be getting the idea now, on how to move on from here. Next, we will go and look at his Rock Gate Park, but there are a few more things to be pointed out to you, as well as an explanation about the earlier comments about the twins and the Oh. Let's, however, first look at one more picture, or specifically the page it is on. Find the two pictures of EDL demonstrating his generator. One is in his little book and the other one on the back of his pamphlet that contains the topics, *Magnetic Base* and *Sound Base*. When you compare these two pages you will find an added feature, which is the dot above the letter **A** of his name at the bottom of the latter page. So what is the significance of the dot above a letter other than it lines up with the hanging **J** and the hoist? Is it a mathematical symbol, or just a typesetter's touch? Next is his last pamphlet with the tiny, tiny print that runs off its back page. How careless, or how on purpose, and that is all there is to it for now!

Regarding the comment about the twins and the Oh! Remember that EDL had his sights on the heavens above. Science and astronomy, you will find, were a great part of his life. The number of stars in the heavens is vast, some say infinite, and there are many twins that can be found in the constellations, the most famous being **Gemini**. The sky also contains the

basis for astrology, the records of the Greek gods from time since past. There is even a Southern Cross whose X may mark a spot in the heavens above. Remember, however, that there is only one recognized X or zero on this earth. It is a simple brass plate with a line drawn upon it in Greenwich England. The Prime Meridian that has the nickname Oh!



Photograph Insert from Greenwich Royal Observatory in England

One last thing to note. Each of his writings contains a "U. S. A.", even his little book. See if you can find it on your own, but don't worry, it will be pointed out later on, in this little book.



If you ever visit EDL's Rock Gate Park, near Homestead Florida, walk through his Coral Castle at least twice. If you walk through it once, you may only see the grand works of stone, because those who visit normally look at it from the inside looking out. When you walk through it the second time view it as a book. A book is not read from the inside out, but from the outside looking in, from cover to cover through it. Read the stone works as symbols that were carefully placed there for all to read. They are in the four dimensions of width, length, height and frozen time.

Now, follow along as we take a short walk through his Coral Castle. We won't go through it all now. We will only look at the things we will need to help us break into his paper writings now and a few for later on. To help you along, there is a map in the appendix of this little book. In fact there are four. Two that will trace out the paths we will take and two for you.

Using the first map, let's ring his bell twice and imagine that EDL would open his West gate ①. As it opens, we would see him standing to our right, to greet us into his Coral Castle, in his Rock Gate Park. The first thing we would notice when we look through the opening of this gate, is his famous nine-ton rotating gate. It sits in the far wall in front of us across his park towards the earth East. If the sunlight hits it just right, it is truly an awe-inspiring sight to behold. If we could walk directly through his Coral Castle by heading/ walking through it slightly earth North of due earth East⁽¹⁾, we would come to his rotating gate at that far wall which was in front of us.

We will pause now short of this earth East rotating gate and stop next to his well ②. His well will be to our right. If we walk to the earth East Side of the well and face due earth West towards where we walked in, we

⁽¹⁾ Leedskalnin, Edward: *Magnetic Current*, The Franklin Press Inc., Miami, FL., August 1945, pp. 6 ln. 5 "That causes the North and South Pole magnets to run in Northeast and Southwest direction" - also look up a compass rose.

would see at our feet, steps that lead down to his well in front of us.③ We would also find at our feet, a small disk shaped stone gate approximately 14 to 16 inches in diameter and about 4 to 6 inches thick. We would need to roll this round gate toward our left, or earth South, to have access to the steps that lead to the water below. We would notice the curve or spiral to the earth South that these steps form, as they would take us down and continue down into the water of the well below. The well also has an old fashion hand crank and hoist to lift a bucket of water up for a drink. To operate this hoist we would need to be on the earth South side of the well, slightly to the earth East.④

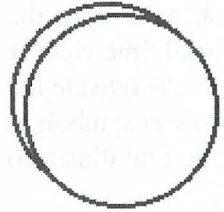

If we would raise some water and take a drink from the ladle, we would be facing his Polaris telescope that rises in the distance. We would not be looking due earth North, but slightly to the earth West. His Polaris telescope is really not that far away, you understand. We can easily see the year of 1940 that he placed upon its earth South face. Now lets walk back to where we were, when looking at the rotating gate, when we first paused. ② We are now once again, facing earth East, as before. If we would look to our left, to his right (2) if he were sitting in, what he called his raised throne room, we would see his line of stone works that he named as the planets Mars, Saturn and the two Crescent Moons. They are positioned up along the top of his earth East wall aligned from earth North towards earth South.

We will now walk earth East through his rotating gate and turn to our left, his right (3), so we are facing earth North.⑤ We will walk along the outside of his wall, past his outside steps ⑥, until we get to his drawing that looks like an elongated **S at the turn**. It looks like an elongated S with a hole, or a circle, in its center. A symbol similar to that used in literature § and also in mathematics \oint , if the line would run up through it. If you could divide this symbol into four parts, you would get a small letter **u**, an elongated letter **p** and the same in reverse for the letters **s** and **o**. You will

(2) *IBID.*, pp. 19 ln. 5 "would be all right"

(3) *IBID.*, pp. 19

also find this symbol on the cover of this little book with just a little more artistic flair.

So what is this separator? It is the spine of his stone book and the beginning and the end of one of his stories, if you take the right path through his stone works. To walk you through it all now would take a lot of time. Besides, we are now looking to identify his thin machine and not if he had hid an X in his stone works that marks some kind of nondescript spot.



So what is his thin machine, and why are we looking for it? The reason is simple. We are going to prove out the path that he laid out before us in quasi Greek. It is hidden in the first line of his *Magnetic Current* booklet. In the appendix of this little book is a reference, so you can look at the path on your own. EDL was from Latvia if you recall, and the Latvian language is primarily based on phonetic pronunciation. It also uses the same twenty-six letters of the English alphabet except for four. If you take the first word of the first line of his *Magnetic Current* work, "This . ." and break it apart into *Th i s*, and use the simple English pronunciation, you will see that we are looking for a thin machine that will sing. It's a simple first riddle to solve. One that you have most likely heard before, but you will find it best to test each of his riddles before you move on to the next. Before we both blurt out the answer, let's walk together through his Coral Castle once more, but now in reverse, retracing our steps to the beginning when we first walked through his **three-sided**, 3-ton, earth West gate. Let's now move away from his **S** at the **turn** and walk back along the wall toward his **four-sided** rotating 9-ton gate. We, in essence now, will be moving to his left, if he were sitting on his throne, and our right, if we were still standing where we were before we walked through the gate. We now see his outside steps ⑥ once again in front of us. They are now along his wall on our right. They are no longer shaped like an L as when we first passed them before. They now are shaped like a backward L, or something like a letter J. Passing these steps we will turn to our right, pause, and look up at his Crescent Moons on the wall before walking back through his rotating gate.⑤ These Crescent Moons that looked like a C looking out, now look like a J looking in. We will now walk through the rotating gate and pause again at his well ② facing earth West, with his

rotating gate at our back. Now when we look to our right, the same direction if EDL were sitting in his throne, we would look past his sun couch and his moon fountain to his Polaris telescope. It is fixed to look up to the North Star, and towards the so-called top center of our universe. Let's continue now and walk back to our start, but first, we will walk to the earth West side of the well and look straight down.^⑦ His descending steps now take on a shape similar to his large Crescent Moon. Let's now turn around and face slightly earth South of due earth West ⁽⁴⁾. We will now go back to his earth West wall through his three-sided stone gate and out from his stone world and back to the world we started from.^①

You guessed the answer to the riddle of the thin machine, of course. Everything will reverse, right to left, when you step through a flat mirror, or a reflective surface like the water in his well and look back. Some would ask the obvious question that we were looking for a thin machine that sings, so how could the answer to his riddle be a mirror? As you read on, you will find out that there is a certain type of mirror that can in fact sing. For now, let's review the path taken through EDL's park. If you noticed, we walked a total of four times, through an opened gate. It also appears that we walked through two different gates and that we walked through each twice. There is a pattern developing here of course, but looking at it, or his story in stone would now take a lot of time. Besides, we have more important things to look at right now, so let's move on.

=====

Using the next map, let's ring his bell twice and imagine that EDL would open his West gate ^①. As it opens, we would see him standing to our right, to greet us into his Coral Castle, in his Rock Gate Park. The first thing we would notice when we look through the opening of this gate, is his famous nine-ton rotating gate. It sits in the far wall in front of us across his park towards the earth East. If the sunlight hits it just right, it is truly an awe-inspiring sight to be . . . **hold on here EDL what are you hiding behind your back that you don't want us to see?** Are you trying to use slight of hand, like a magician, and force us to look and be drawn to your rotating gate, like a moth to the light of a flame? So he is, as you will now see. It is small, in fact something that you would overlook when you

⁽⁴⁾ *IBID.*, pp. 6

would walk through his park. It is on the earth North side of his earth South wall in line with the earth South corner of his barbecue. In fact you would need to stoop forward, bow or kneel in a position of atonement to look at it. It is a small hollow in his wall that is the shape of half a sphere, and the second beginning of his stone book. One that will make more sense, when we reflect it's meaning into his paper works. But there is more, so let's move on.

=====

Let's take a closer look at his rotating gate. A picture of it is shown with Clueless a few pages back. You will notice that his 9-ton rotating gate when closed will look like a broad fat "I" and when it is open like a "T", so when spinning the gate would spell out the word IT. Using the first map, let's stand once again next to his well and face his rotating gate by facing earth East. ② Let's have someone start this gate spinning. For a frame of reference, let's have this gate spin left to right, or counterclockwise like the path of the planets about our sun, if we could look down on it all. Now go through the gate. Make sure it is not spinning fast when you do, 9-tons of rock with all that momentum, could crush, bend you in half, and make a mess of you. So now when you are standing outside ⑤ of his East wall, turn around and look back to the earth West at his rotating gate. The gate that was spinning counterclockwise left to right will still appear to be spinning the same. OK, so what? Now turn so you are facing earth East with your back to the gate. Take out you mirror, your thin machine, and look at the reflection of the rotating gate. While you're at it, straighten out your hair from the blowing wind. You don't want to stand out like a weirdo and start to draw a crowd. If you now look at the reflection of the spinning gate with your mirror you will see it now appears to be spinning in reverse. So what else is new? Now take out your second mirror. You did bring two didn't you? Now while facing earth East, position both mirrors so you can look at his rotating stone gate again. Watch out, people are starting to look at you. You better get out your comb and comb your hair before they start to walk over to see what you are doing. So what do you see besides two of you in reverse or into infinity, when the reflection bounces back and forth between the mirrors? With the two mirrors the reflection of the gate is corrected and the reflection of the gate spins right again. OK, so what was that all about? Well its normally not polite to answer a question with a question, but here

it is. How come you couldn't see through the mirrors and observe the trees in the earth East when you were looked at the reflection of the spinning gate? Also, sometimes it can be difficult to disguise what you are really doing or what you have done, unless you use a little wit when you turn things around. The thin machine or mirror we are looking for is not a standard mirror, but one that you can use like a two way mirror, which will be looked at in the chapter entitled *The First Machine* of this little book.

There are a few more things to cover now, which we will need later on. The first one has to do with his rotating gate once again, in addition to his barbecue. Envision it is pitch black with not a star in the sky. You are standing next to his well once again, looking earth East, facing his rotating gate.② On the other side of the gate ⑤ is a uniform wall of light, like the dawn. As the gate spins you will see two columns of light that will start from the outside as slits of light like this | | which will then grow moving toward the center like this ■ ■ and move outward back to this | |. Now envision it is again pitch black, with not a star in the sky. There is a uniform vertical column of light in the center of his barbecue. Now instead of standing still as before, you now walk (5) around his barbecue. It doesn't matter which way you walk around it for now. All that matters is that you look towards its center towards the light. You will see a column of light that will change, from one to two and back to one again, in a special pulsating way. Don't forget that you also walked, or passed, through these beams of light. You will see this pattern when you read on, but it's time now to start talking about the **two machines** we will need, to break into his work. The need for two machines is again a continuation of the path that he laid out before us in quasi Greek. If we take the second word of the first line of his *Magnetic Current* work, and use the simple English pronunciation, you will see that after we o-tone, or atone as we did, there will be an exchange between two machines. The first one will fuel the second; the second will refuel the first. As always there are other meanings to this, and the rest, but we will stick to this path for now unless EDL tells us otherwise. We now need to quickly gather some additional information that we will need later on, so let's not waste any more time and press on.

(5) *IBID.*, pp. 11 ". . the currents are in motion and you are, too. "

Envision for a moment that EDL's park was his private refuge from his world of man, just outside his massive walls of stone. Imagine for a moment that this refuge was his little heaven on earth, where he could set the directions of North and South, up and down any way he wanted inside the bounds of his world. The same could also apply to his East and West. In fact everything could be reversed ⁽⁶⁾ for a better phrase, or even keep moving about, just like being in space in a rocket ⁽⁷⁾ ship, or under water in a submarine. There is one frame of reference he appears to hold, being what we call the top center of the universe.

For those of you that remember a clock with hands, to correlate his 9 and 3-ton gates as the numerals 9 and 3, which you would find on a mechanical watch face, may be a chore. The problem would be to determine, if you were looking from outside of the watch looking at its face, or from within looking out. The same would apply to the directions of East and West from the magnetic North and South Poles. If you were facing the earth's North Pole (*enp*), the direction of earth East, as being to the right of *the enp* would be correct. The same would be true if you were looking down on the earth with the top of your head towards *the enp*, but reversed when facing earth South, or if you were in the center of the earth looking out. The reason is because the direction of earth East has no *end*, since it is a curved line that runs parallel to the surface of this earth sphere, and nearly perpendicular to the geo-magnetic

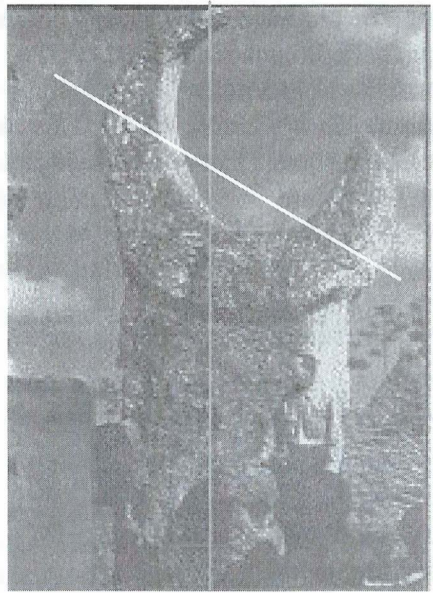

Photograph published by Coral Castle, Homestead, Florida with one added line

(6) *IBID.*, pp.13 ". . . ,then the running would be reversed."

(7) *IBID.*, pp.19 ". . . the rocket . . ."

field of the same. As stated before, there is one frame of reference EDL appears to hold. His Polaris telescope is the clue, since it is aligned on one of the infinite number of lines, or vectors, that converge at the so-called top center of the universe, which you must remember, does not necessarily mean earth North or even his North when looking *out* from this earth.

Speaking of looking *out* from the earth along a vector line. Does the direction up always mean up all the time? Even if you look down through a transparent earth, once you would pass that point, or center of the earth, would you not be looking out, or up to the sky and some where into the universe? So let's agree on one thing now. The up that we find in the first line of his *Magnetic Current* booklet, and its corresponding title line on page 3 of that work as MAGNETIC CUPRENT aligns along a line. A line that runs perpendicular through a **relative frame of reference**, or **center point**. So if we take the 15 letters in MAGNETIC CUPRENT the eighth or center letter from either side is C. If we draw a line through it we get the standard ζ symbol which stands for **centerline**, MAGNETI ζ CUPRENT. EDL also gave us the same clue if you look at his picture on page 31. The added line points to the so-called top center of the universe.

So, when you (fold it up as a U) and read it you (U) look East,

↓				
↓	→		<i>This meaning would only apply for this</i>	*
M		T	<i>respective line only please.</i>	T
A		N		N
G		E	<i>Remember its all relative, which would make East</i>	T
N		R	<i>in the first line of his work to mean E as T, giving</i>	R
E		P	<i>us the starting line of characters for his first machine,</i>	P
T		U	<i>and his instruction to C (see) U → → →</i>	↑
I	ζ	C		
			<i>It also gives us the symbol Ψ to now think about.</i>	

There are a few more things we will need to start to break into his writings of course, but since we are still in his park let's look closer at EDL's East wall with his stone planets, Mars and Saturn. It's important for you to know, so let's now give it some life and purpose since we may need it later on. If his Mars and Saturn are lined up along a separator, that separator should be the Celestial Equator. The Celestial Equator as you recall, aligns with that of our earth. It is just a flat imaginary thin disc

shape that happens to line up on a fictitious plane, which can be viewed from anywhere in space. Although Saturn and Mars, as he has on his wall, can be found along the same Celestial plane, they are **normally** a little bit further apart if viewed from this earth. They are only observed next to each other on certain dates, or spans of time. At any other time it's almost like seeing a reflection in a looking glass, but not a standard mirror. You would need a two way mirror that you could look through to see one, as well as seeing a reflection of the other from behind you, but not always exactly 180 degrees behind. This mirror that we have been talking about, like his 9-ton gate, is not standing still, since it needs to turn around to keep things aligned. As you will see this is one interpretation, but of course EDL has given multiple meanings to a lot of things, so how about a date? If you look to the appendix of this little book find May 20, 1946. It is the date EDL used to end his pamphlet discussed on page 18 in chapter 3 of this little book. If you would **look out from his park and the earth** on that date, you would see Mars, Saturn the earth moon and something to do with Venus, which relates to his small Crescent Moon, in almost the correct relationship on that date. The picture shown for May 20, 1946 in the appendix of this little book follows the alignment on his wall when looking East except for two things: the phase of the moon and the rings of his Saturn in stone. His stone moon is Waxing, but the moon that rose at approximately 9 PM on May 20, 1946, was a Waning Gibbous . The reverse of what he has in stone when looking East. The ring on his stone Saturn tips up to the right / instead of to the left \ as seen through a telescope. So what is necessary to get things right? We will need to turn things around, or mirror things about. The picture shown for May 20, 1946, in the appendix of this little book, placed us at the top center of the universe looking down. We need to look up instead, since he keeps his Polaris telescope trained on it all the time. There are a few more things we need to do to get things right, as shown in the appendix of this little book entitled:

 May 20, 1946

The upper bar is a symbol that means not or reversed

EDL gave us another date in that pamphlet being Feb 3, 1946. It has an interesting thing if you are looking for a symbol. Another would have to do with Dec 7, 1951 the date of his death, which has to do with Neptune

and the symbol Ψ we found earlier and the phase of the moon on that date. You will see how it all will tie into his writings, but for now let's look for another meaning while we are here. We have three dates, so there should be a fourth, since EDL evens things out with dual meanings to a lot of things. So how about a view through the plane of our solar system, from some where out in space? The question now is, from where out in space we would need to look? To find it would depend on two things, if you would try to find it from this earth. You would need the time (year, month, day and hour of the day or night), when you would look up to see it, along with the proper point of reference from this earth to look up from. Relatively speaking, of course.

Now, let's talk a little bit about geometry for a moment. Ugh, Geometry. Brings back memories doesn't it? If EDL was using the ways of ancient times long past, it would be no surprise to find a Golden Rectangle, or two. Take a moment to draw EDL's rocket in his Golden Rectangles, which are inside the borders, on the covers of his twin booklets. The ancient Greek mathematicians would also be proud to see you using a bow compass, as you start to draw their Golden Φ . Remember, however, as the bell rings

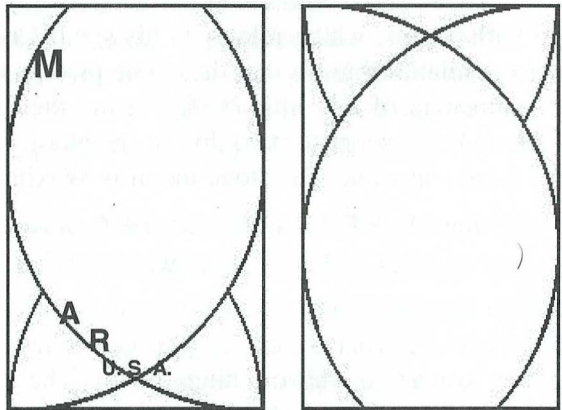

twice EDL's rocket can be drawn two ways, either pointing up or pointing down. No matter which way it is drawn, there is one common thing you will see missing. Where is the rocket's nose cone? Is the rocket going up to the moon, or did it fall back down with its nose cone buried in the sand? You will need to pick one, or both, but here is a suggestion where you can start. As light bends around a high gravity field, see if you can find the curved line, the **thread** as another thin machine, which lies on his Celestial Equator. Its the curved line with the planet Mars on it. Also remember that both of EDL's twin cover pages contain a U.S.A., and so do both pictures of him with his HOIST, like the one in his little book. His

hoist contains the letters U.S.A. that are upside- down, of course. You will find an illustration of this hoist and the words on it to aid you, in the appendix of this little book. As we will continue, the turning mirror that we found on page 33 will be of importance, since we will use it break into his writings, as you will see. However, there is more to just breaking in to his writings as you proceed. Remember, that although someone can put you in a car and show you how start it and how to drive it, the car will be useless unless you learn how to drive it along the path you want to take. You will need some basic knowledge of a few things that you may find by reading some reference books or from a quick search of the Internet. However, the most important thing you will need, you already have, it is your wit.

Well let's continue on with geometry now, because we need some numbers, in fact not two, but three. Let's start with a point like the period at the end of this sentence. A point is a point of course, but it is just a point in space. Two will give us the coordinates, which a line passes through. Three a plane in space and four, well there is a slight problem with four. Four can trace out a two-dimensional square, rectangle or rhomboid or could be the four-corners of a three dimensional pyramid. As you see, as we increase the number of points the possibilities get quite large, and since his title line has fifteen, MAGNETICCUPRENT, which way do we go? Again, if we are dealing with using the ways of ancient times long past, it would seem logical to look to **the sacred number nine**. With fifteen points we can fill up one rectangle that is five by three which adds up to nine, you see (C).

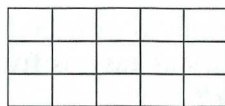
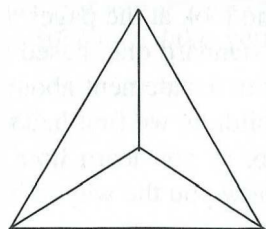

Now all we need now are two words that will fit. They must be four letters each, so let's test our wit. Take one of the thin machines and put it up to his twin works and see if you can find them. Don't worry if you cannot find them now. You will be told what they are in just a little while, because there is something you probably suspected all along, so let's get it out in the open. The man known as EDL, you will find, had a diverse background in many fields of knowledge, and life experiences. He was,

you will discover, a true being of his time. We, as he, take the many paths in our life as it unfolds. We take the opportunities that come to us akin to a falling leaf pushed by the winds of family, jobs, love, war, patriotism and the politics of the day. Some paths we take in our life we cannot completely control, at least not at the time they occur. As we get older, or more knowledgeable and aware of our mortality, we change. Some of us earlier than others and some of course never do. Some of us even pick up the book known as the bible and read about our ancient recorded past. Would it surprise you that it was the basis of EDL's knowledge and to all that learn how to read between its lines? If you ever read some of the passages from the bible you we see the same type of phrasing and repetition that EDL uses in his published works. As suspected, it is no coincidence. The bible, remember was the word of God put to print on paper by man, for man to read and understand. If you have one, dust it off and look at the pages at the beginning of that book. If yours happens to be a standard one, based on the King James version, you should find a page with a statement about the goals set down, when it was put into print. As children, we first had to learn how to read, so we could learn on our own. So, as you learn how to read EDL's writings, EDL, in his fashion, will show you the way to his secrets, as he shows you how to read his writings too.

So did you find the words ROCK and GATE? Let's now gate the word **gate** by opening it up as **g ate** and turning it around to obtain **geta**. What do you think EDL would tell us if we asked him how to break into his writings, or how he moved all those stones? How about, **get a rock you see** it's as easy as five one three. Or maybe it should it be one, two and three?

Well anyway, we also will need one more way in. It is fortunate for us that it is (Leedsk**aln**in) all nine (1+3+5=9) at the start. All we will need will be the other four-letter word. How about, ". . . when you **read** it you . ." ⁽⁸⁾. So let's gate the word **read** by opening it up as **r ead** and turn it around to obtain **r dae** for a thin machine that will sing, **ETA DAE**. What does it all mean? Let's learn by reading on.

(8) *IBID.*, pp. 3 ln. 1

On page eleven of EDL's *Magnetic Current* booklet he states that he used ten machines ⁽¹⁾ to make his magnetic currents. As we have seen so far, some of these machines move to the right or left, some turn some need to be folded and some you have to walk around. The one he refers to, as being the most efficient is the one that we will use to break into his writings. It is the one that sings, or in a better sense of the word echoes back. As EDL tells us on page three of his *Magnetic Current* booklet, ". . . *it will be just as good for your electricity . . .*" ⁽²⁾. On page four, ". . . *you will see how it works.*" ⁽³⁾

Before we start, however, there is one other machine you should know at least something about. It's the dollar bill he mentions in his newspaper ad. For the sake of time we will only look at two things you can do with a dollar bill, but you will get the hang of it. For the first one, take your

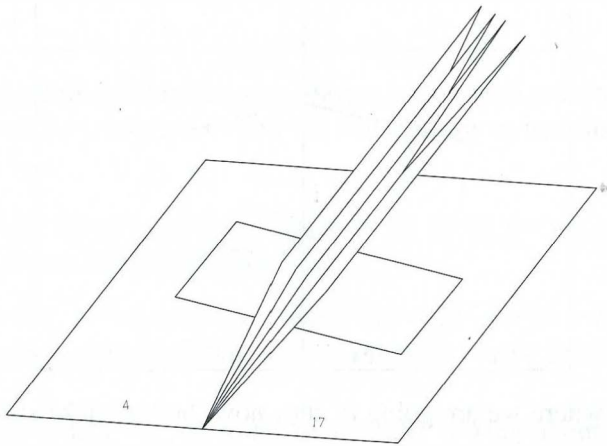

dollar bill and slip it under pages 5 through 16 of his *Magnetic Current* booklet so it lays flat on the sheet of paper that pages 4 and 17 are printed

⁽¹⁾ Leedskalnin, Edward: *Magnetic Current*, The Franklin Press Inc., Miami, FL., August 1945, pp. 11

⁽²⁾ *IBID.*, pp. 3

⁽³⁾ *IBID.*, pp. 4

on. On page 4 find the line "*you will see how it works*". Above it is the word **rod** followed by a comma. Position one corner of the dollar bill on this comma and the other corner of the dollar bill at the comma, on page 4, between the words **long** and **two** in the line, ". . magnet about three inches long, two and . .". (4) If your dollar bill is positioned just right, when you go to page 17 you should see the bottom edge of the bill block out the words

the currents be . .
begin to slant, but . .

We agree that they do. However, if you now flip the dollar bill onto page 16 without disturbing its position at the center there is more. The important thing to see on page 16 is that if you follow the edge of the dollar bill down you will come to an upper case letter A.

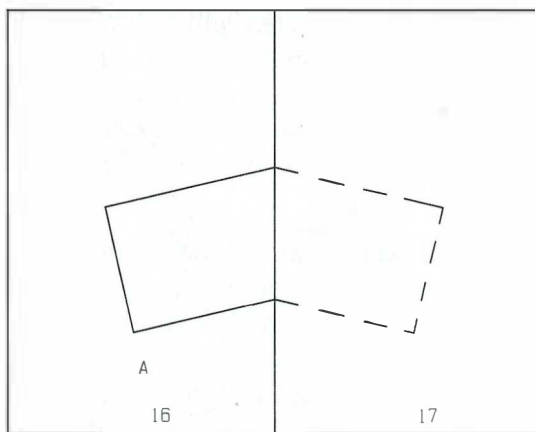

This is not where we are going to start now, but do make sure you visit it later on.

For the next solo dollar bill trick, pull your dollar bill out from under the pages and fold the dollar bill in half lengthwise so the green back is facing out. The fold will run cutting the two circles containing the All Seeing Eye Pyramid and the Great Seal of the United States of America in half. These two half circles form something that looks like two U's.

(4) *IBID.*, pp. 4

Turn the dollar bill so that the bottom of the pyramid is to your right. Find the word **Break**, it is the first word of the second paragraph from the bottom. Directly below the word **Break** are the words **to go in**. Put the bottom \supset so the lower end of this side ways \supset by the word **NOVUS** trails the words **to go in**. If you follow the loop you will get the phrase **to go in**

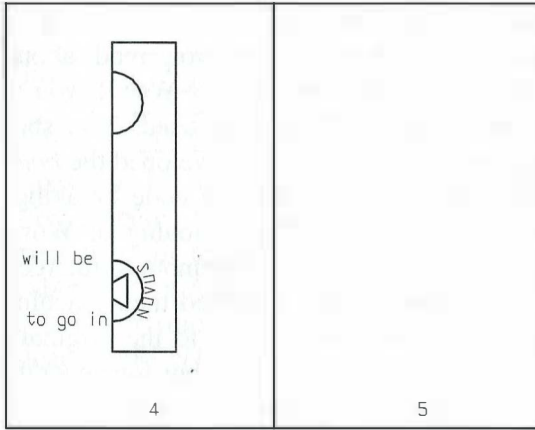

be will. These dollar bill tricks were shown to you for a reason of course. You will need them later on to find the other entrances into his writings if you wish.

So let's begin by doing what EDL tells us to do on page four of his *Magnetic Current* booklet that starts at,

"the Equator. Now you get the equipment and I will tell you so you can see for yourself that it is in the way I have told. Get a" (5)

So what equipment do you think he is really talking about? It is 1945 remember, and World War II was finally at an end. EDL was a man of business and science. Men of finance and science had to be very cautious in their transactions, so don't you think that EDL would have used his enigma machine? The enigma machine if you remember was originally developed for protecting civilian transactions between banks. The commercial encoding machine was fairly effective, but as all things had its

(5) *IBID.*, pp. 4

limitations since it only had 3 operable encoding rotors and one thick reflector rotor or Umkehrwalze. The machine got its stigma during World War II when the Germans added a modification to the machine and used it for encoding their military communications. The modification was to add plug in wires, or Steckerbrett that exchanged a few letters around. This dramatically decreased the possibility of someone decoding an intercepted message since these steckerbrett wires further increased the number of machine combinations by thousands. If you read about the enigma machine and its use before and during World War II, you will see it was an effective encoding machine if properly used. You should also read about Alan Turing, a mathematician, who developed the *bombe* which was an advanced improvement over the enigma code breaking tool that the Polish discovered and used during the beginning of World War II. To counter the Western allies, and Turing's attempts to intercept and decode their messages, the Germans further modified their machine by adding a fourth rotor position and three more rotors to the original five to select from. This now gave the machine not three but four operable rotors with one of two thinner mechanical versions of the old Umkehrwalze. This improved enigma machine further increased the number of set up combinations. It was almost virtually impossible to break into the code in a timely manner. This last version enigma machine was developed for use by the elite German submarine forces as well as their State Department personnel. This elite enigma machine was only part of the encoding process, however, because they would not work without the spooks, the nickname given to those who operated them. These men and women were the ones that received the encoded message in Morse code, typed it in the enigma machine and wrote out the decoded message. The reverse was naturally true when they sent the encoded message out. You can imagine that as time went on these spooks slipped in their own personal messages within the official transmissions as they started to talk to the other spooks. Well we got off the subject of breaking into EDL's writings so let's get back on track, its starting to get a little spooky.

Now, in reference to page three of his *Magnetic Current* booklet *it will be just as good for your electricity*, set your standard three ring commercial enigma machine as follows:

Modell 3	Or Abbreviated As	M3
Grundstellung or G set to YOU		GYOU
Ringstellung or R set to YOU		RYOU
Umkehrwalze or U set to C		UC
Walzenlage or W set to 123		W123

Now if you type in the coded message as the letters PRENT from the previous chapter,

Input line

P	R	E	N	T
---	---	---	---	---

Output line

A	M	P	S	I
---	---	---	---	---

the decoded message is AMPSI. AMP is the accepted international abbreviation for ampere, the unit of electrical current. Also, when electrical current used in a mathematical formula the letter I is used instead of the abbreviation AMPS for amperes. So in essence *AMPS=I, it will be just as good for your electricity*. Now clear the machine and type in PRTNT instead of PRENT.

Input line

P	R	T	N	T
---	---	---	---	---

Output line

A	M	B	S	I
---	---	---	---	---

Instead of getting AMPSI you get AMBSI which really makes no sense at all.

So you can see that besides having the right settings in the enigma machine you also needed to type in the code in the correct sequence. The blessing which the Poles/ Polish code breakers and Alan Turing had going for them was that the machine acted like the mileage wheels of an odometer as in your car. The code wheels instead of being set with the numbers 0 to 9, were set with 26 positions with a preset combination of the letters of the alphabet as shown below for the commercial enigma machine:

Rotor1 = "EKMFLGDQVZNTOWYHXUSPAIBRCJ"

Rotor2 = "AJDKSIRUXBLHWTMCQGZNPYFVOE"

Rotor3 = "BDFHJLCPRTXVZNYEIWGAKMUSQO"

Rotor4 = "ESOVZPJAYQUIRHXNLFTGKDCMWB"

Rotor5 = "VZBRGITYUPSDNHLXAWMIQOFECK"

RotorB = "SLVGBTFXJQOHEWIRZYAMKPCNDU"

RotorC = "CJGDPSHKTURAWZXFMYNQOBVLIE"

The commercial enigma machine allowed you to install any three of the rotors 1 through 5 and one of the two reflectors B or C. The unused rotors and reflector would normally be stowed in a storage compartment in the machine. The settings we are now using in this commercial version machine use Rotors 123 and the reflector C. Rotors 4 & 5 and Reflector B are not used. The words YOU and YOU set up the relationship of the rotors to each other and the rings on each rotor. Simply put, it would be like having your odometer preset to some random mileage number like 00786 for an example, but again there is more to it than that. The blessing in disguise as eluded to earlier, was that if you misinterpreted one letter such as PRTNT instead of PRENT the remainder of the message would play out correctly, AMPSI vs. AMBSI. The main problem is that if the rotors were ready to cog, such as when your odometer would go from 00999 to 01000 the message would get completely garbled. The same was true if you left out one letter in the sequence. So to take an intercepted message and successfully decode it there was only one true set up that would work and one true message to type in. If not, it was GIGO, garbage in garbage out.

Now let's realize that the decoded message AMPSI is not the one we want. As EDL stated, IT (the machine) *will be just as good for your electricity*. What we want to see is what EDL told us on page 4 of his *Magnetic Current* booklet; you *will see how it works*.

So let's set up the machine again but now with the settings, M3 GETA
ROCK UC W513

If we type in coded message PRTNT we get OPGZJ.

Input line	P	R	T	N	T
Output line	O	P	G	Z	J

So what happened?

Don't worry the word WORKS is there but is hidden in the machine itself. Remember what EDL said, ". *when you read it you*",⁽⁶⁾ so let's see the letters that were on the reflector or Umkehrwalze inside of the machine.

⁽⁶⁾ *IBID.*, pp. 3

Input line	P	R	T	N	T
Umkehrwalze	W	O	R	K	S
Output line	O	P	G	Z	J

Sneaky little devil isn't he!

We could leave you here and say good-bye but all we have done so far is show you how to start a car. It shouldn't surprise you that this message is just to tell you that you're on the right track just like the AMPSI message before. We have quite a ways to go yet before we even get to the right car or machine set up and use. So why is he being sneaky? Well let's have him tell you in his own words. Remember this is not the message we are looking for now since the one we want will be at the Equator, but by continuing a little further we will see what we are really up against. To do this we will have to look at the input, Umkehrwalze and output lines all at the same time from here on out. So get out your enigma machine or load up your enigma software and follow along. If you don't have enigma software you will find it for free on the Internet. The best software version to use is a DOS version. Although you might think that a Windows version would be better, you must remember we will need to look into the machine not just at the input and output lines.

We will keep the same settings as before M3 GETA ROCK UC W513 and heed his instructions at the bottom right side of the second paragraph on page 4 of his *Magnetic Current* booklet, "up rod inch it".

So what **ROD** is he talking about and where is it in his booklet?

If you go to page 19 you will see there are three paragraphs on that page. The last paragraph has 18 lines for the 18th letter of the alphabet or **R**. The middle paragraph 15 for **O**, and the first paragraph has 4 lines for the letter **D**, giving us **ROD**. So let's now continue as follows by adding **This** from his first line:

Input line	P	R	T	N	T	T	H
Umkehrwalze	W	O	R	K	S	I	T
Output line	O	P	G	Z	J	X	N

If you now continue typing in the line *This writing is lined.* the message breaks off because we must heed his instruction, *when you read IT you look East*. Well the Umkehrwalze does read **IT** so let's now look East and

inch up the ROD. It's your call of course how you would inch up page 19, and try all you may think but ask yourself this. If we are to go in the direction of R O D, where does the rod start? How about the page number 19 as AI but looking East ← of course as → 91 or IA. So let's type it in

						9	1		
Input line	P	R	T	N	T	T	H	I	A
Umkehrwalze	W	O	R	K	S	I	T	E	Z
Output line	O	P	G	Z	J	X	N	U	F

WORKS IT EZ, well it has been far from EZ don't you think?

We continued from the 19 as 91 looking East, so is there a Sacred Nine? Yes there is on his copyright page, remember his aide 1945? (4+5=9)

							9	1	4	5	
Input line	P	R	T	N	T	T	H	I	A	D	E
Umkehrwalze	W	O	R	K	S	I	T	E	Z	D	L
Output line	O	P	G	Z	J	X	N	U	F	O	X

So now you will see what we are up against since, when we follow the U, we find that **Ed** is a **Z fox**. You will see that EDL is a master of the enigma machine amongst other things. There is also a UFO in the output line, which we saw pop up in chapter 2, "The Clues and Symbols", of this little book. For you hopefuls you will see a UFO pop up again but not as you would think it to be when you read on, but let's now continue.

If you now pyramid around the L of his name on the copyright page as indicated in the first chapter of this little book you will get the following:

		9	1	4	5						
Input line	I	A	D	E	E	R	E	A	D	W	S
Umkehrwalze	E	Z	D	L	Q	D	P	R	P	Q	M
Output line	U	F	O	X	X	X	X	O	W	C	L

So deer read w. . . with hugs and kisses? Well his hidden messages are in fact letters of a type to whoever finds them are they not? The hugs and kisses **OXXXXO** are really a marker for the letters blocked out in the Umkehrwalze that will take on an entirely different meaning when you learn what to do with them later on. You can continue on of course but

for now let's clear the machine and take one more path up the rod before we get to the Equator.

We will keep the same settings as before M3 GETA ROCK UC W513, type in PRTNTTH for **WORKS IT** and experiment with a different path for now. Let's now look at all those hyphens *lined up so* that you have seen throughout his *Magnetic Current* booklet. If you look around you will see the path taken with his hyphens that works up and back towards the start of his *Magnetic Current* booklet. Remember, however, that we are at **THE END** of his booklet that ends with the word **LIGHT**.

In	P	R	T	N	T	T	H	E	E	N	D
U	W	O	R	K	S	I	T	D	I	P	I
Out	O	P	G	Z	J	X	N	T	C	M	B

In	L	I	G	H	T	D	S	Y	N	R	E
U	W	X	M	N	I	Y	M	R	I	N	C
Out	P	O	N	T	O	U	L	G	P	G	F

In	G	T	E	E	E	E	H	E
U	T	K	V	M	F	X	Z	C
Out	O	L	A	H	T	D	J	V

So what can EDL be telling us?

Well you will have to remember that if you were writing this as standard enigma message, each word WOULD~~X~~NORMALLY~~X~~BEX~~X~~BLOCKED out with a letter **X**. You can see, however, that EDL does not follow the standard way to confuse the message. Kind of makes you wonder if this man of science was trying to block the Germans from reading his message too. Let's learn from this. He seems to be using the letter W when applicable to go in two paths such as WORKS IT DIP I LIGHT or WORKS IT DIP I ONTO. He also pops through the Umkehrwalze at will such as for the word IT. He also uses the letter D when applicable for the word THE and the X a possible exchange of lines and so forth. Here is one possible way to read this message.

WORKS IT DIP I ONTO IT, D (THE) SLY G IN C. FOLK
RING TEEEE HE

So what is the joke? We will see it later on in this little book, but for now let's get back to the Equator since it has the encoded message that we will need to type into his second machine later on. If you read a few of the lines that EDL wrote above his Equator on page 4 in his *Magnetic Current* booklet, he tells you that the keys are its center(s) as shown below in upper case letters as follows:

yOu cAn sEe fOr youRself thAt it is in the way I have told. Get a

Now if we use the same settings as before M3 GETA ROCK UC W513 we get nothing but gibberish as shown below.

In	O	A	E	O	R	A
U	N	U	C	G	E	J
Out	P	T	Z	R	G	F

The question would be why? The answer is in the previous chapter entitled *The Thin Machine* since we are now going to pass through his first gate. So the setting ROCK would now change to RDAE giving us the settings M3 GETA RDAE UC W513 to use. Also, since we are at the Equator, we need not look at the Umkehrwalze, but you can look at it yourself if you wish. So let's now type in the following letters again shown in bold "*yOu cAn sEe fOr youRself thAt it*" and see what we get:

In	O	A	E	O	R	A
U	↑	↓	↑	↑	↓	↓
Out	L	N	B	W	M	T

LOAN BE WORM AT . . .

We are now at the word **it** (*you can see for yourself that **IT***), so EDL wants us to now use our wit and look East.

So let's go to page 11 at the middle of his *Magnetic Current* booklet. See the worm?

(Have in mind that always there are two currents, one current alone cannot run. To run they have to run one against the other).⁽⁷⁾

⁽⁷⁾ *IBID.*, pp. 11

However, how about a second meaning? EDL always has at least two if not more?

Remember that EDL was also a religious man, so how about a biblical interpretation or symbol that has a worm in its center like an apple? The Cc could be two bites taken from it, could it not? Also, when his West Rock Gate opened could it not have revealed his heaven on earth with a song *ETA DAE?*

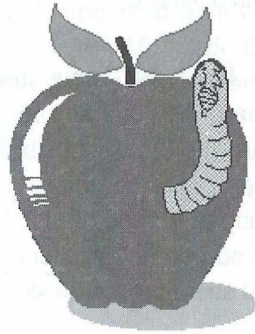

Well, let's continue on to his second machine for his joke. For some of you it won't be a joke, especially if you look at the message just as words alone, but when viewed as symbols it will make sense of what it is all about.

For those of you disappointed that there is no treasure map, don't feel down. You will see some of it pop up as we continue on.

For you UFO hopefuls the same will also apply. You see there is a lot in EDL's writings, in fact so much it could never all be covered in this little book. That is why you are being shown the way in. From this you will see how it really works. However, always be leery of that hook and be prepared to walk away if you feel its pull. Remember that some go fishing just for sport with a baited hook on a line. Some use a net to catch their fish. Some go fishing for other things than fish, because some are fishers of men too.

Before moving on to EDL's second encoding machine let's look at some Golden Geometry. We need to clear something up first and besides this chapter is rather short since it is only a few pages long. Some who read chapter 4 may have raised a questionable eyebrow or two when they saw the reference to a **Golden Rectangle** when constructing EDL's rockets. You are now being reassured that you didn't sleep through geometry 101, since there are no Golden Rectangles to be found using the borders as presented on EDL's cover pages. If you would go back to chapter 4, page 34, the sentence read ". . Golden Rectangles, which are **inside** the borders . .". So why are they inside the borders? Let's construct a Golden Rectangle and find out. If you go to the appendix of this little book, you will find an instruction sheet on how to construct a Golden Rectangle. The ratio of the sides of the resultant Golden Rectangle is 1:1.618... If we look at the border on EDL's *Magnetic Current* booklet you will find it to be approximately 1:1.736..., which is of the wrong proportion. The same would apply, to some extent, if you would look at his twin pamphlet entitled, "*Mineral, Vegetable and Animal Life*". You can, however, make one fit in each as shown below and draw the arcs to make his rockets,

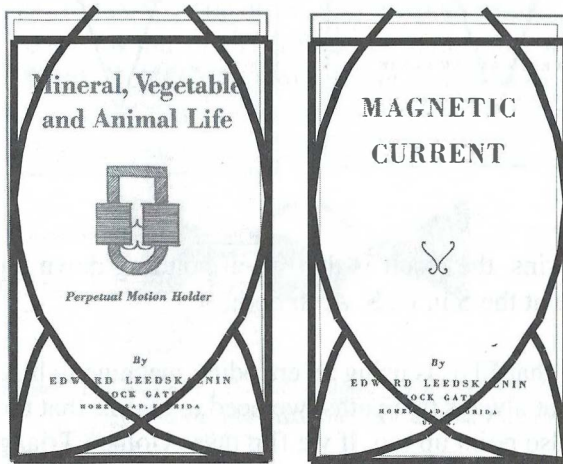

Cover Inserts- Leedskalnin, Edward:

Magnetic Current, The Franklin Press Inc., Miami, FL., August 1945

Mineral, Vegetable and Animal Life, The Franklin Press Inc., Miami, FL., October 1945

which converge at the S in U. S. A. in both.

What needs to be pointed out is that there is some Golden Geometry hidden inside of EDL's borders of importance. It is not the Golden Rectangle but a Golden Triangle instead. If you go to the appendix of this little book, you will find another instruction sheet on how to construct a Golden Triangle. When you would construct a Golden Triangle on the

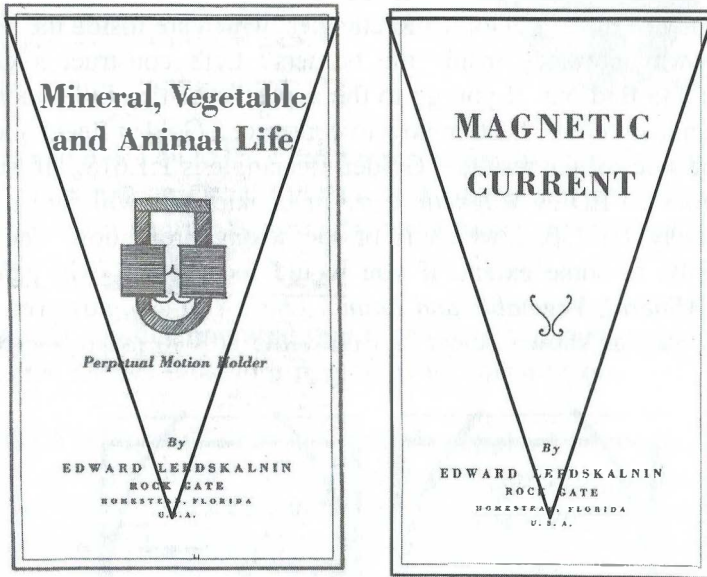

covers of his twins, the result is that when pointing down they both once again, converge at the S in U. S. A. in both.

Since we know that EDL is using an encoding machine to hide his secret and that there are always two paths, we need to realize that these Golden Triangles can also point up too. If we flip these Golden Triangles around there is a message in each as follows.

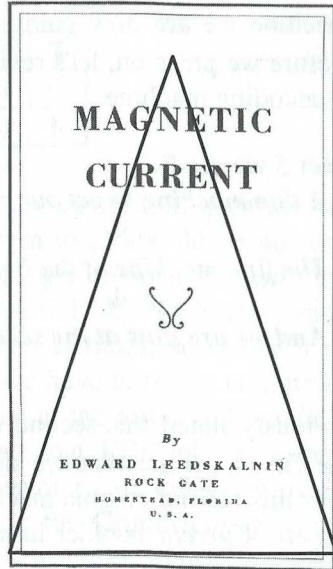
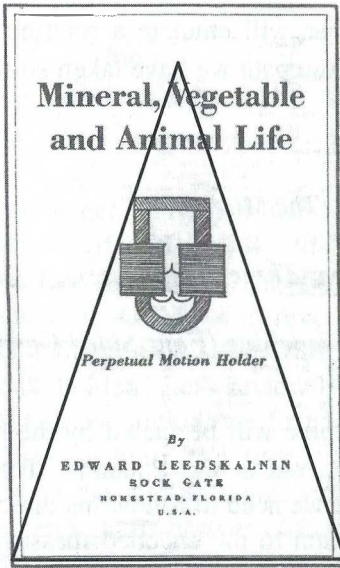

The one tells us "I'M A V". The other, if you would excuse EDL's spelling is "NER R", maybe for mirror. There may be some other messages that could be seen here which may become clearer to you as we move on. In any event these Golden Triangles seem to track with the symbol that we see in his little book as reproduced below.



Insert from - Leedskalnin, Edward: A Book in Every Home, Privately Published by Edward Leedskalnin, Homestead, FL., 1936.

Let's now move onto EDL's second encoding machine and see if he tells us more.

The machine we are now going to use will emulate a rotating gate of sorts. Before we press on, let's review the path we have taken so far using his first encoding machine.

In Chapter 5 we used:

A thin machine to get our start (The Mirror)



The first machine at the Equator (Three Sided Gate)



And we are now at the second machine (Four Sided Gate)

As previously stated this second machine will be fueled by the message from the first machine that we deciphered at the Equator. To get the setting for this second enigma machine we need to follow his directions in his *Magnetic Current* booklet in addition to the encoded message in his newspaper ad as follows:

- On page 11 of his *Magnetic Current* booklet, EDL tells us that we ". . . transformed currents in kind."⁽¹⁾ He also tells us we will need more turns for a higher voltage, which means an enigma machine with more rings, or four instead of three.
- In his newspaper ad he embeds a message that C is a fib which means to use a B Umkehrwalze instead. He also states that W is C, or the previous C Umkehrwalze is now in the Walzenlage for WC513. (Box the H as HMHXBH and use M3 GETA ROCK UC W513).
- We already have seen that CUPRTNTTH → CUWORKSIT → SEE U WORKS IT in G of course for GWORK.
- And let's not forget to ring the bell twice for RRING.

So let's set up our enigma machine with the settings, M4 GWORK RRING UB WC513.

⁽¹⁾ Leedskalnin, Edward: *Magnetic Current*, The Franklin Press Inc., Miami, FL, August 1945, pp. 11.

Before we type in the fuel or message from the first machine, let's type in the word IT and look at the result.

Input		I	T
Umkehrwalze		G	G
Output		M	E

The result we get is IT ME which is EDL's way of telling us we are on the right path, but if EDL follows his pattern there should be not one but a few more messages here. The next two are obvious as being the word TIME and G IT GEM, or in reverse GEM IT G. So is there more? We know EDL likes to be sneaky little devil at times, so where would this message be hidden? Let's review how we have used the enigma machine so far. When we started, we first looked at the input and output lines of the enigma machine. We then realized that EDL placed some of his messages on the Umkehrwalze or reflector rotor. Let's now look at the machine settings themselves, specifically the Grundstellung in reference to the message GG. When we set up the machine, the Grundstellung was set corresponding to letters that spelled W O R K. If we now show these rings as they change with typing in the letters IT we have:

Input		I	T
Umkehrwalze		G	G
Output		M	E
		↑ ↓	↑ ↓
Grundstellung	}	W	W
		O	O
		R	R
		K	L
			M

For a message to GET the WORM. Sounds like he is fishing again. We could stop now and speculate what worm EDL wants us to get, but there is no need, since EDL told us it was a loan or aide for us to use.

So let's clear the machine keeping the same settings of M4 GWORK RRING UB WC513 as before, and type in the message he gave us at the Equator *loan be worm at halfuc*:

In	L	O	A	N									
U	H	U	G	U									
Out	W	S	H	P									

When we type in the word loan we get HUGU or hug you that we are on the right path. Let's not overlook the message wshp which could be worship as with the UP N. If we continue to type in the rest we come to the word WHY where the message breaks off.

In	B	E	W	O	R	M	A	T	H	A	L	F	U	C
U	R	R	U	Z	O	T	Z	T	L	G	V	Y	K	Y
Out	R	W	A	N	H	Y	T	C	Q	D	Y	W	H	Y

So where would our worldly wit draw us to continue the message but to type in KYOU

In	K	Y	O	U
U	H	I	G	C
Out	J	O	K	E

Which leaves us with his riddle **WHY JOKE**. So what joke is he talking about?

Since we know EDL leaves more than one meaning in his messages, there is more than one joke here to look at. One is of course a simple joke or the sneaky little devilish prank he played which we will look at first. The other really isn't a joke at all, since there is an ancient symbolic meaning of having incomplete sex. We will look at the simple prank now and discuss the other later at the end of this chapter, where things will start to come into perspective. For now, the prank or joke we will look at is the resistance or obstacle we would have encounter weaving a dollar bill through the pages of his *Magnetic Current* booklet. There is nothing wrong with using the dollar bill method of course since you would

eventually get to the same place in his writings as we will get to using an enigma machine. The difference in using an enigma machine is that we will have an insight to draw a different conclusion that would be missed using the other methods and paths he left. Without this insight you would be stopped cold when you see it with no idea of what it was all about or where to continue next. Well, let's get back to the simple joke he played. It was the resistance or obstacle he placed in the way of using the dollar bill method to find his hidden message. The obstacle is naturally the staples we would encounter, which for a better phrase would be to our right side or our East as we would read across page four of his *Magnetic Current* booklet to its spine. So let's continue by typing in STAPLES EAST and see what we get.

In	K	Y	O	U	S	T	A	P	L	E	S	E	A	S	T
U	H	I	G	C	L	C	F	I	T	E	D	E	C	S	O
Out	J	O	K	E	L	D	C	Y	G	F	C	C	O	L	J

By refueling this machine with our wit we get the staples in the East lined up so | _ _ | as symbols for the letters **L** and **J**.

We now need to decode this last message. The next machine we are going to use will emulate his three-sided gate to get out of his park. Before we press on let's review the path we have taken so far.

We used:

A thin machine to get our start (The Mirror)



The first machine at the Equator (Three ring)



A second more complex machine (Four ring)



The next machine would be the same type as the first (Three ring)

Before we use it let's repeat the lines from the second machine.

The line of text we are interested in is the output line of this second machine shown in bold text below.

In	L	O	A	N	B	E	W	O	R	M	A	T	H	A	L	F	U	C
U	H	U	G	U	R	R	U	Z	O	T	Z	T	L	G	V	Y	K	Y
O	W	S	H	P	R	W	A	N	H	Y	T	C	Q	D	Y	W	H	Y

In	K	Y	O	U	S	T	A	P	L	E	S	E	A	S	T
U	H	I	G	C	L	C	F	I	T	E	D	E	C	S	O
O	J	O	K	E	L	D	C	Y	G	F	C	C	O	L	J

The next or third machine should be the same type as the first, but since we are no longer at the Equator the settings will not be M3 GETA RDAE UC W513. At the Equator you would need to envision that we are in fact weaving back and forth between two hemispheres, be it the one of the earth, a plane in space or one of ideals. The question would be which two hemispheres are we weaving between. The clue he gives us is in the key words needed to set up the enigma machine, ETA and DAE. If you look to the scriptures you would find that the words IOTA and the ETA indicate the Savior's name while the DAE would relate to the Daemons, demons or fallen angels. In essence we are weaving between that line or Equator, that is between heaven and hell, life and the grave the seen and unseen. Since this is quite profound, let's now just envision that the line that we are weaving between at this Equator as being between the heavens and earth. It is a simplified view of course, but at least we have used an enigma setting of M3 GETA ROCK UC W513, or ETA for the heavens and ROCK for the earth. So let's now set up our enigma machine and enter the message from the second machine and see what we get.

In	W	S	H	P	R	W	A	N	H	Y	T	C	Q	D	Y	W	H	Y
U	H	A	I	C	E	L	K	G	S	Y	V	D	G	W	B	C	F	N
O	M	M	R	J	G	J	E	O	O	R	A	R	M	K	V	D	O	B

In	J	O	K	E	L	D	C	Y	G	F	C	C	O	L	J
U	G	R	O	C	J	Z	E	Z	K	R	O	R	H	O	Y
O	L	S	F	F	N	F	Z	Q	R	R	B	R	Y	O	R

As you see we do not get any readable message at all and to pull one out would be a stretch. So what should we do? Let's use our wit, or ω it, and

turn it around by entering them in reverse order with the pretense that we are in fact retracing our steps or a path we took before.

	↓		↓																
In	J	L	O	C	C	F	G	Y	C	D	L	E	K	O	J	Y	H	W	
U	L	Z	H	Q	G	D	L	H	E	D	J	Q	L	B	M	S	F	O	
O	B	O	L	Y	W	A	Y	B	E	O	P	X	U	J	F	Q	O	U	
													↑						↑

In	Y	D	Q	C	T	Y	H	N	A	W	R	P	H	S	W
U	R	S	X	L	B	V	Y	G	Y	A	S	N	P	X	J
O	G	E	E	K	B	N	Y	O	Q	V	F	B	N	C	I

We now get a message in the output line of the enigma machine. **BOLY WAY BE** naturally does not read correctly, as you would agree, so there must be a reason it came out that way. The question would be if **BOLY** should read **HOLY** or **BODY**. Let's explore **HOLY** first since to change the **BOLY** to **BODY** we would simply need to type in an **F** instead of the **O** in the input line which really doesn't tell us anything. To get the first word to read **HOLY** instead of **BOLY** we would have to type in a **Y** instead of a **J**. So how about **Y HOLY WAY BE** or **WHY HOLY WAY BE**? The question would naturally be **what**, since the message trails off as you see. However, if we look down the output line of this third machine we see another encoded message bracketed by two **U**'s as **UJFQOU** which we will look at now.

So what is the Holy Way? Well there are two meanings of course. As far as an enigma machine is concerned it would be the initial condition or the standard settings of an enigma machine when first received as **M3 GAAA RAAA UB W123**. So let's set the enigma machine up with those settings and type in **JFQO** and see what we get.

In	J	F	Q	O
U	L	I	P	S
Out	S	K	V	M

We get **LIPS**. This message was also seen before if we would have looked at the message we decoded earlier as **AMPSI** in quasi Greek. If we would

break it apart into two pieces⁽²⁾ as **AM PSI** we would get *Am Lips*. If we broke it apart into three pieces as **A M PSI** we would get *Father Man Lips*, symbolic of a story to be told or passed on from father to son. In any event we get **LIPS** for the decoded message. If we use the **HOLY** path we get a question that EDL now asks of us, **WHY HOLY WAY BE LIPS?** If we had used the word **BODY** we would get a statement **BODY WAY BE LIPS**. So what does it mean since EDL normally leaves two messages with two paths to take? Let's look at **BODY WAY BE LIPS** first as to locate the **body** of EDL's hidden story and discuss the other message or question **WHY HOLY WAY BE LIPS?** as we go on.

Let's go to the cover of EDL's *Magnetic Current* booklet and place our thin machine or mirror's edge across the wide spacing of the two curved lines. If we would look at both the reflection and the curved lines on that page they would look like lips that is if there was a line drawn between them. Notice now, no matter where you are in relation to the page when you look into the mirror you will only be allowed to look to the bottom of the page where the U.S.A. is printed. That is the path that will lead one to the hoist at the back of his little book, which is the path that one would take if they were not using an enigma machine. You will be shown what is in that path at the very end and a little bit more in the appendix of this little book. For now we will take a different path since there are two. Notice that when you were looking at the reflection of the lips that the **LEED** in his last name Leedskalnin now reads **ΓEED** or **REED**. If you were using an enigma machine it would draw your attention. The word **REED** would be interpreted as a setting for the **Ringstellung** since it is a four letter word that starts with an **R**. Also, if you would have some knowledge of electricity you would also see a connection here, since $D \text{ (the) } E^2R$ would equal power. So what is EDL telling us to do? What **reed** is he talking about? Well let's heed his message and get out his little book since both paths point to it for now. Instead of going to his hoist in the picture where he is demonstrating his

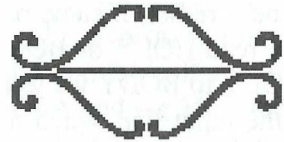

(2) IBID., pp. 3

machine we will instead look for the reed or reeds first, because it is also a thin machine that would sing like a reed flute.

So let's get his little book and open it *up* so the pictures on both back and front covers are facing out. Look at these pictures and look for the reed or reeds since there is at least two and most likely more. Look at his Moon Fountain on both the front and back covers of his little book. The one on the back cover is void of reeds while the picture on his front cover is full of them. If you have a moment get out your magnifying glass now and look closely at the front cover of his little book. Look at his left shoe. See the white shape that looks like a skewed up side down triangle. Now look at the bottom right of that cover page. Do you see a familiar triangular face?

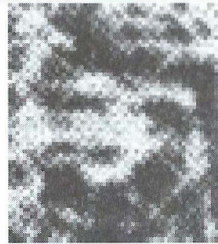
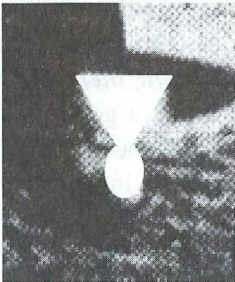
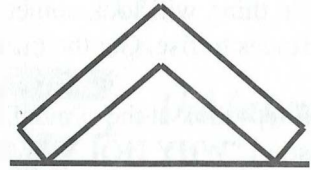

Inserts from - Leedskalnin, Edward: *A Book In Every Home*, Privately published by Edward Leedskalnin, Homestead, Fl., 1936.

For you UFO hopeful's it will look like the typical triangular alien's face we have all seen. Let's see, the Roswell incident was in July 1947 was it not, but his little book was published in 1936. A dilemma unless EDL new something back in 1936 or maybe it was a good guess or just a coincidence. While you have your thin machine out **let's take a look at his rivet**. Get his pamphlet entitled, "*Mineral, Vegetable and Animal Life*". Line up you mirror as you did on his *Magnetic Current* booklet, but now so the bottom of his Perpetual Motion Holder picture looks like



an O. Some would say it would look like a symbolic communion host. However, move the mirror up towards the title. You will see the O change to a θ shape, like the planet Saturn or a lined up O. If you keep moving the mirror up you will see the rivet and then you will see it break and then the whole thing will look something like a rocket free of earth's gravity as it continues to rise. Get the picture?

Well let's look at the symbolism to the reference of incomplete sex and the question "**WHY HOLY WAY BE LIPS?**" What could it mean? Did you ever see a picture of, or if you were fortunate to travel to Florence Italy, Vincenzo de' Rossi's statue of Hercules and Diomedes in combat? How about Michelangelo's Youth conquering Brute Force? There is a lot of symbolism in them as well other ancient sculptures and paintings left for us to view, especially if we connect them with the interpretations of the ancient Sumerian depiction's, engraved on their so-called stone cylinder seals. Envision that there was a time when man had a knowledge that far surpassed ours about chemistry, the human body and the genetic program that we are now starting to understand as with the makeup and structure of DNA. "*I have never studied human anatomy, but I know there are many little cords* ⁽³⁾ . . ." How did EDL know or was it a just a good guess? If you have no idea what this is all about, including the theories of man's acquired gift to procreate, then it's time that you looked into it in depth. When you are there also read about a sexual act that was forbidden of the ones that were given the general title of the gods. Read how they would be banished and stripped of their status, fallen angels for a better name, if they joined with an earth woman to procreate. Also, read about the biological tricks these gods played on each other to attain power, or dominion, by tricking the other to consume their seed or chemical potion they would disguise in the other's food. You will see that there is more to EDL's writings than just gibberish as there is more to the tales of those mythological Greek gods in their struggle for power. When you are ready then read EDL's pamphlet. The one that starts with the question, "*What is Life?*" ⁽⁴⁾, of course don't forget the rivet that holds it all together.

⁽³⁾ Leedskalnin, Edward: *Mineral Vegetable and Animal Life*, The Franklin Press Inc., Miami, FL., October 1945.

⁽⁴⁾ *IBID.*, pp. 2.

As far as the message that was uncovered, here is yet another path to consider since we substituted a Y to get an H to change BOLY to HOLY. Instead of dropping off the B let's keep it as YB or Y BE HOLY WAY. It has to do with both the make up of light and magnetism especially if you use a U shaped magnet and interpreted the Y as γ or a Greek symbol for gamma as shown in the picture to the right.

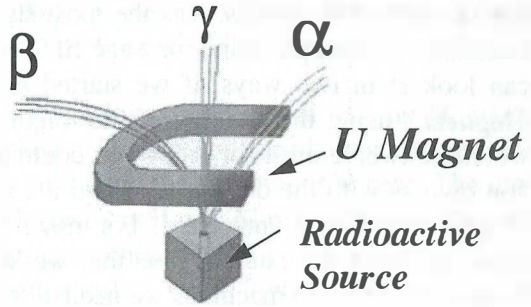

Let's now get back on track by interpreting this message as BODY WAY BE LIPS. It's EDL's way of pointing us to it the main body of his writings by using the reeds. Don't forget the S that we saw before as the up side down U. S. A. in his hoist, since they both lead to his little book.

Before we continue let's once again check the path we took:

The thin machine to get our start



The first type of machine at the equator for the first message



The second type of machine for the second message



The third machine was the same type as the first



The fourth machine was the holy one



The thin machine once again to restart

In essence we went in a circle just like traveling about the Equator, or a loop of wire in a coil for an analogy to electricity. It also, however, could be a reflection that we are seeing. A reflection between two mirrors that will be looked at in chapter 8 entitled *Light*. What will be pointed out to

you is the inefficiency that a mirror has and why we looked at the message that took the path of the holy way that escaped during the last reflection above. For now, we started our path at the Equator, because there is but one in each of his works. It is the most significant one to take because it contains the most profound message EDL wants to tell, and as always you can look at in two ways. If we started at "*The North And South Pole Magnets*", using the analogy of the longitudinal lines of the earth, there would be twelve orbits or loops you could take. These you can explore on your own as with the one Equator and the messages in his other pamphlet or twin if you are interested. For now, however, we will look at the significance of the number four that we keep seeing pop up now as the number of different machines we needed to use to get at this last message, the four missing letters in the Latvian alphabet and of course there is more.

The following will be directed to those of you that are astronomers, but let's all heed it for we all can learn from what it says. In the previous chapter it was eluded to the fact that a heavenly message is written in the stars for us to read. The problem would be where to start and then the path to follow if not two. As discussed earlier, to identify where we would need to look would require the time of the day, and the date (day, month and year) as well as from where on this planet we would look up. The where is in his *Magnetic Current* booklet, but again you have two choices to choose from. The year was previously discussed, but you will see there will be a choice of two. The time of the day and month is what we will look at now. If you were aware of how to tell time aboard a naval ship, you would recognize the significance of the two bells when you enter his park. But without knowing the approximate time or the four hour naval watch of the day, you would not know if it was 0100, 0500, 0900, 1300, 1700 or 2100 hours that the two bells ⁽⁵⁾ would be telling you to look up to the sky. However, when added with the quasi Greek reference to the dog in the first paragraph of his *Magnetic Current* booklet, we now know there is but one possible choice. However, we must remember that there are two quasi Greek dogs as there are two dog watches in a 24 hour day, one that has two bells and one that has four. Two bells when we entered his park

⁽⁵⁾ See *Naval Watch in the Appendix of this little book.*

and two when we leave for four. Well at least we now have two times during the twenty-four hour day to look up to the sky instead of twelve. For us that are not astronomers it also means that we also can take two dog watches or paths through his park, one previously discussed and one which we will explore a little more at the end of this chapter.

To get the month we need to get out his pamphlet that has his *Magnetic Current* advertisement. We looked at it before in the chapter entitled *The Clues and Symbols*, which also contained the first possible year. The clue is in the date 5-20-46. We could just say it was May and be done with it but let's look at it with the enigma machine just to check since there may be more. Also, let's tie it in with the last word "light" at the end of his *Magnetic Current* booklet. So set up you equipment with the settings from the second machine and type in MAY LIGHT and see what we get. The plural lights will be used because there will be, as always, most likely two.

In	M	A	Y	L	I	G	H	T	S
U	Y	O	U	X	T	W	I	N	S
Out	I	V	B	J	N	O	R	Z	L

So if you are adept in astrology this will be a clue for you as to the months and the other possible year to choose from. The day is the interesting one of course. Who knows, maybe it has to do with how light will bend around our sun to get Mars and Saturn to line up so, the phase of the moon or maybe an eclipse?

Now let's look at the map. Some of you have been waiting for this.

Set up your equipment to M3 GETA ROCK UC W513.

Get out your magnetic Current Booklet and by using the same method previously used for the word ROD give each of his paragraphs, both on their right and left side, the corresponding letter of the alphabet as with the number of lines ends found. As an example on page three you would have the letter B on both sides of the first paragraph and C for both sides of the second and so forth. Note that some paragraphs will not have the same letter on both sides.

The path taken to get this message will be obvious by the encoded message typed into the machine below. The U line is for you to look at if you wish.

In	P	R	T	N	T	B	F	E	C	C	E	F	C	K	Z	G	O	D
U																		
O	W	O	R	K	S	H	I	D	E	A	L	P	I	N	E	M	A	P

WORKS HIDE ALPINE MAP . . .

If you have the time and the wit you may find out where the ALPINE MAP will take you, but don't forget there is the word of GOD here too.

Well let's get back to the dog watch. The question now is when we took this last dog watch which path did we really follow. Take out your map of his park and see if this makes sense. Maybe we were inside of his park, his heaven on earth, when the bell rang twice. Maybe we walked out not in his West gate. Maybe we walked to our left as we walked outside of his walls to enter the sans door gate at the barbecue by his Equator carved in stone. Maybe once inside his heaven on earth we then went to our right. Maybe we then went down and back up his water well steps. Maybe we then walked outside of his stone works through his rotating gate and into his East Garden of Eden. His stone works are in fact only a potion of his Rock Gate Park.

Get you machine and set it up as follows GETA ROCK UC W513. Now let's go to the **beginning** he does reference it twice in his *Magnetic Current* booklet does he not? Type in the following and see if you want to see where it goes. Remember, however, we never put in the wires, steckerbrett, to exchange a few letters around. You be the judge if you want to find one of the messages that pertain to the past.

In	A	D	A	M									
U	A	N	D	I									
Out	Z	J	P	U									

ADAM AND I . . .

Close your mouth now or you might swallow the hook, because if you type in Adam and Eve and use the correct steckerbrett connections the U

will read *and if gem in*. If you typed in **Adam an Ed ro** . . with the correct steckerbrett connections the U will read, *and if gravi* . . Up lifting isn't it.

Now go back to page eleven of EDL's *Magnetic Current* booklet and read his line or worm at the center of that published work.

(Have in mind that always there are two currents, one current alone cannot run. To run they have to run one against the other).⁽⁶⁾

If one current is light the other will be dark. Is it not the cosmic force? Let's shed some light on the subject as we move on to chapter 8 entitled **Light**.

⁽⁶⁾ *Leedskalnin, Edward: Magnetic Current, The Franklin Press Inc., Miami, FL., August 1945, pp. 11*

So what is light, why should we care and why does EDL end his *Magnetic Current* booklet with it?

We all sat through some science class some where along the way, so what were we told about light? No matter what definition or explanation you want to use to describe what light is, there is one interesting thing about light. You can't catch a light beam and hold it in a can, can you?

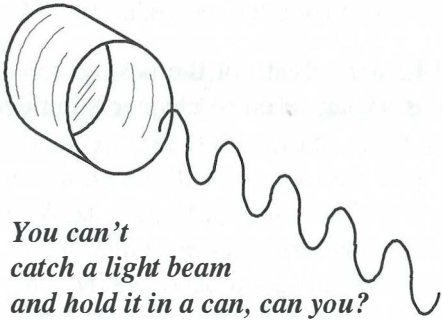

*You can't
catch a light beam
and hold it in a can, can you?*

Silly isn't it, well how about this? Some would of course argue that you could in fact capture the light and hold it in a can, but the can would need to be traveling at the speed of light, which is impossible of course because a can that is traveling at the speed of light that holds the captured

light would then need to have no mass at all, because a can that had any mass that would hold the captured light would itself approach infinite mass as it nears the speed of light, so then if the can that is traveling at the speed of light that holds the captured light has no mass what is the world can the can be? Whew! Well, you were told it would sound silly, but isn't that what we have been told is the truth?

*Well, you were told it would sound silly,
but isn't that what we have been told is the truth?*

So if that is the truth, why not this. What if someone would tell you that a can of infinite size could capture and hold the beam of light? So nothing has really changed from before since a can of infinite size would also have infinite mass. You need a can of infinite mass to catch and hold a beam of light regardless if the can is moving at the speed of light or standing still.

You need a can of infinite mass to catch and hold a beam of light regardless if the can is moving at the speed of light or standing still.

It seems that it is impossible for us to catch a light beam using a can, so maybe there is another way which is beyond the realm of silly, in fact at the border of sounding quite preposterousness. Maybe you could in fact catch a beam of light just by reaching out and using your hand. It would of course be difficult to prove that is if you expected to see a beam of light just sitting in your hand.

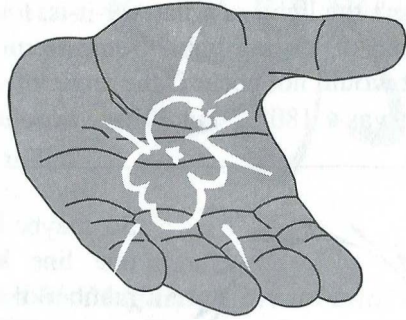

Let's face it, no matter what your definition of light is, electromagnetic radiation, pure energy, the massless photon or a speck of blue cheese; you cannot see light unless your eye first transforms it into something that your conscious being recognizes as light. So what does this have to do with catching a light beam? Everything!

*So what does this have to do with catching a light beam?
Everything!*

How can it be everything? Well let's continue to try to catch a light beam with something other than our eye and see what happens when we do. How about using a mirror to catch a beam of light? EDL used a mirror to hide his writings; in fact we found he normally used two. So how about trapping or oscillating light, or whatever-it-is, between two mirrors

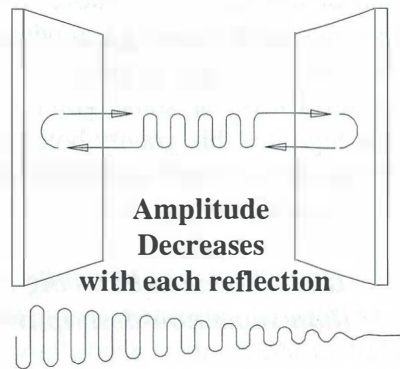

instead of using a can to catch a beam of light? Well maybe we could if there were such a thing as a perfect mirror that we could use. Doesn't a mirror, even a first surface mirror, or any efficient reflective surface really first absorb and then re-emit the light, or whatever-it-is, so it really doesn't truly reflect as we think. Also, every time it does this reflection task doesn't the light, or whatever-it-is, loose some energy, or whatever-it-was, instead of loosing light? Some would argue that the above absorption of light would not occur if the angle of incidence that the light beam reflects by was 180° , but that would get us back to a straight line.

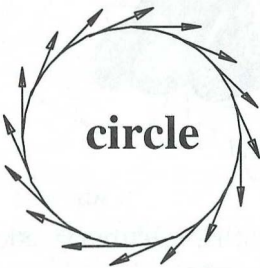

So maybe the clue is not one line but an infinite number of straight lines or tangent lines that would make up *a circle, or to go one more step a hollow sphere*. This circle or hollow sphere could not



have any internal surface imperfections, an impossible task to fabricate as with the chore to get the light to pass through its outer shell to run around inside.

Or instead of reflecting light off of any surface at all, how about just bending the path of the light, or whatever-it-is before it becomes light, by using a gravitational field? Can we not bottle it up, the light or whatever-it-is, in some gravity bottle? So how big does this gravity bottle need to be? Does it need to be as big as the infinite universe or smaller than some non-descriptive point in space like a black hole?



Does it need to be as big as the infinite universe or smaller than some non-descriptive point in space like a black hole?

So if we could bottle up light, or whatever-it-is, in a gravity bottle is then the reverse possibly true? Could we possibly bottle up gravity in a bottle of light, or whatever-it-is could be? Also, if we cannot see or sense light until it is absorbed are there other things that are around us that we cannot see? So why in the world did EDL end his Magnetic Current booklet with light? It's a simple answer of course; he wanted to open our eyes, and our minds, so we could see.

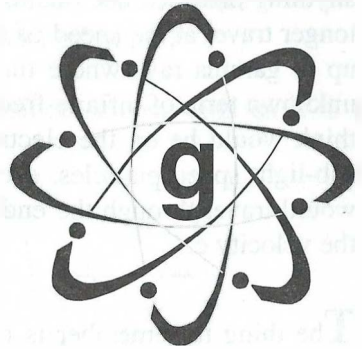

So why in the world did EDL end his Magnetic Current booklet with light? It's a simple answer of course; he wanted us to open our eyes, and our minds, so we could see.

Under it all, what we refer to as light is really an interesting thing you see. Without it, our optical sensors, *the things we call the rods and cones in the retina of our eyes*, would not be stimulated and therefore we could not perceive sight. With too much of this thing that we call light they would be over stimulated to the point where we would become effectively blind. So whatever light is before our optical sensors absorb it so we see it as light; we are, for lack of a better phrase, created or designed to only see what we were allowed to see.

we are, for lack of a better phrase, created or designed to only see what we were allowed to see.

Every advance that science has made has expanded our limited vision of what we cannot see with our eyes alone. Science has told us that the visible light that our eyes can sense is only a small portion of the electromagnetic spectrum that all of the whatever-it-is, is. Science also tells us that everything on the electromagnetic spectrum has its own inherent frequency and intensity, and they all move at the speed of light but only when in a vacuum. If these massless things travel through

anything else, science has told us that they slow down a little bit and no longer travel at the speed of c . These are the radio waves, light, x-rays, on up to gamma rays where the sight of science then ends, and where that unknown term of infinite frequency begins. Cosmic rays, which we would think would be on the electromagnetic spectrum, we are told, are really sub-light speed particles, even though a 10 Hz electromagnetic field that would travel through the endless vacuum of space would still be travel at the velocity c .

The thing to remember is not to confuse a 10 Hz electromagnetic field with 10 Hz of sound, since sound is a different beast.



since sound is a different beast.



So if you see sound on an old electromagnetic spectrum chart then your old chart must be wrong. We have been told that sound is perceived as a pressure, not electromagnetic radiation. Sound cannot be transmitted in a vacuum so that is why you should not find sound on an electromagnetic spectrum chart. Sound is transmitted by air, solid, fluid or something that must have mass to compress, but again pressure or sound is something we cannot perceive until we are first touched just like the whatever-it-is that we call light. We can feel sound because it is a pressure that causes something to move, but we cannot feel light unless it is first absorbed as the resultant heat of what we call the energy of light. So what we refer to as light before it becomes light is really something we cannot see or sense unless we absorb it in some way first. It is different than sound of course since light does not need any mass to continue on its path or to propagate.

The thing that science tells us is that electromagnetic waves, or whatever-it-is, can pass through the empty vacuum of space, as radio waves, light, x-rays and the gamma rays where the sight of science ends. So how does light propagate or travel through the infinite vacuum or emptiness of space?

So how does light propagate or travel through the infinite vacuum or emptiness of space?

Science is shrewd with its answer since science tells us it is a

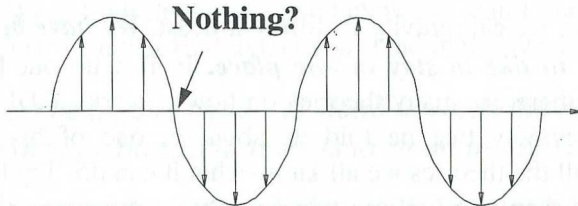

transverse wave of both electric and magnetic energy. So if you could see this transverse wave of the whatever-it-is how would we perceive it?

How about a wave of something that turns into nothing and back to something again,

How about a wave of something that turns into nothing and back to something again, that is of course if you could slice it in half and only look along and through one plane that it travels in space. If you could perceive the whole thing, science has told us, we would then see an electric field running perpendicular to a magnetic field in some direction

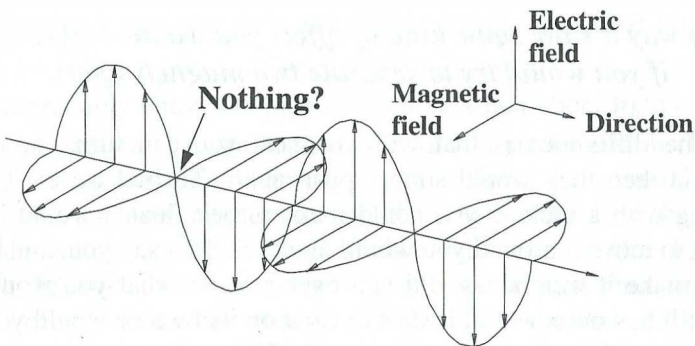

at the velocity of c .

Wouldn't it be interesting if science would one day tell us that this transition of nothing was really something instead? Maybe science has already told us, in their own round about way, since science has told us it all travels along the unit directional vector of time you see.

Even the thing we call gravity is different beast. *We have been told that gravity seems to like to stay in one place.* In fact no one knows what gravity is but there are many theories on how it works. EDL even had a theory about gravity that he told us about in one of his papers, but regardless of all the theories we all know what it can do. Try lifting a rock some time and then you will see why gravity is sometimes referred to as something like sticky glue.

Try lifting a rock some time and then you will see why gravity is sometimes referred to as something like sticky glue.

You first need to exceed the gravitational force or weight, friction and inertia of a rock before it will first start to move, since it is at rest or some say asleep. Once you can do that, and if you could lift it high enough like a rocket, it would then break away from the gravity field of the earth. In a sense it would be like a free body then, as it would continue to travel through space. In a way it's the same kind of effect you would experience if you would try to separate two magnets apart.

In a way it's the same kind of effect you would experience if you would try to separate two magnets apart.

The difference is that with magnets you can turn one magnet around and then they would simply push apart. To bad we can't do the same thing with a rock. If you could make a rock float it would be easy and quick to move it around you would agree. So let's say you could take a rock and make it weightless, did you ever wonder what you would see? Since it still has mass would it start to float on its own or would you need to give it a push to start it on its way? If a rock became completely weightless, would you need to be careful on which side of it you would choose to stand?

If a rock became completely weightless, would you need to be careful on which side of it you would choose to stand?

So if the earth spins towards the dawn at the horizon in the East, a weightless rock that would just rise up would surely appear to move up towards the West. So it might be a good choice to stand towards the rock's East, but isn't strange that EDL tells us to stand in the West instead.

So it might be a good choice to stand towards the rock's East, but isn't strange that EDL tells us to stand in the West instead.

In any event, the reason why you would need to be careful with a weightless rock is that it would become dangerous when it would move. A lot of mass even at a slow velocity would still contain a lot of momentum to stop. It could be the same as being crushed by a rock falling on you due to some low level of gravity. So if you could get a rock to be completely weightless it would in fact be dangerous to control. It would be better if it was not completely weightless. A little bit of gravity would act like a light chain attached to the rock to make it easier to handle. So lets see the interesting thing that happens when we crack a magnet in half at its Equator. If you could break one in half and try to put it together would it not try to push apart? It would seem that something happens at that crack in the magnet's equator to make it then repel instead of attract.

It would seem that something happens at that crack in the magnet's equator to make it then repel instead of attract.

So you probably know where all this endless talk about light and the rest is going, since we now are at the last **S** in silhouettes and the things you can see or perceive when you use your inner sight. As a general summary, our eye first captures the electromagnetic radiation that is in the frequency range and intensity that we call visible light. This visible light passes through the lens of the eye and is focused, or converged, not on the inside surface of the retina but inside its wall where the rods and cones, or photoreceptors are found. There this visible light, or electromagnetic radiation, energizes the photoreceptors. Each acts like a micro radio receiver antenna that is tuned to the bandwidth, or frequency range, of the electromagnetic radiation we call light. The rods are sensitive to changes

in brightness or intensity, while the cones are sensitive to the minute changes in frequency or what we call the color of light. These

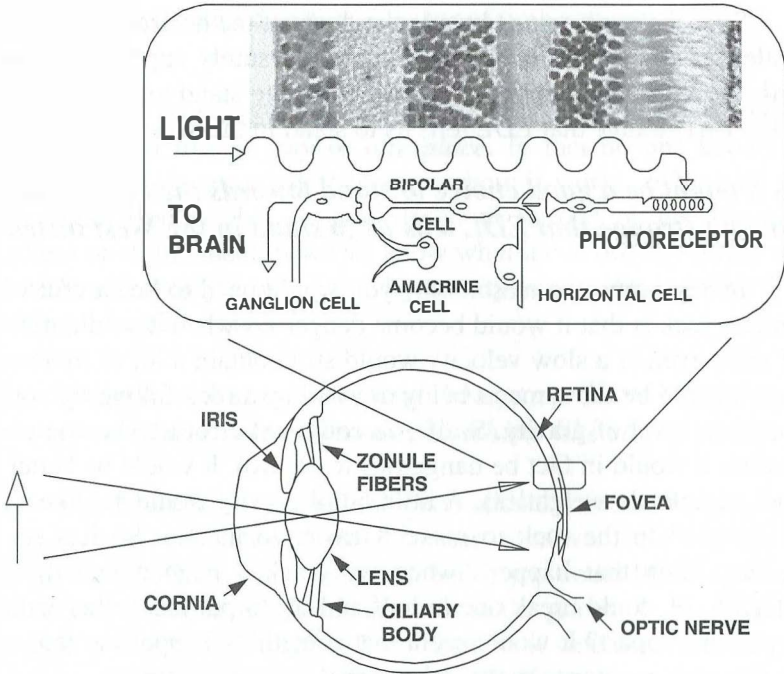

photoreceptors sense this information akin to the dots you would find in newsprint or the pixels on your computers monitor screen. A bioelectric signal is created which first travels $\rightarrow \leftarrow$ against the direction of the light, and then along the curved retinal wall where they converge into the optic nerve bundle. These signals in turn are connected by this optic nerve bundle to our brain where they are processed not by brightness, but by comparison to construct lines and then curves so we can perceive what we see. In essence, we see our world as patterns of lines, even things as complex as your multi-dimensional hand in front of your face. When the intensity of the electromagnetic radiation is sufficient, we can perceive color over and in the gray or black and white picture we see. When the intensity of the electromagnetic radiation is low we can only perceive things in black and white or as the many shades of gray that we experience at the two edges of our 24-hour day as dusk and dawn. Of course, let's not forget that in a camera as in our eye; everything is reversed, where up is

down and right is left or where an A could be lined up so ∇ . Some may also question if black and white were also reversed, but that question has no real significance since there is always a shade of gray somewhere at the Equator between them both. The real question to think about instead would be if the Equator was still the Equator or is the Equator now really the poles?

How we see light is really an amazing thing, a gift we would all agree except if we were blind. We could explore each of the remaining senses that one being blind would have, but instead let's start with none at all. Imagine what it would be like with no sound, smell, sight, taste, touch, heartbeat, breathing or any physical sensation. The seed of our conscious being would then be surrounded by everything we could experience in our life, but we would be unable to sense or understand any of it, like it was not there at all. If we furthermore had no previous base of knowledge, or understanding, we may have just described what we were at our conception into this dimension of life.

In essence, what we can see with our eyes and sense with our bodies, and all our man made sensors that we know of today, may still not tell us what it is really all about, or what is really all about us. We are merely naive children when it comes to understanding a form of deception, on a cosmic scale, that our eyes and our mortal senses play on us. Is it because we can only see and sense what we are allowed to see and sense after it touches us first and is properly absorbed? Or do we merely lack the proper knowledge, insight or sensory capability to comprehend the Equator of the truth leaving us to rely on blind faith alone? As a coarse analogy, light, sound and all the things that stimulate our senses are like the silent unseen bullet that fells the unsuspecting soldier on the battlefield of chaos. Although the bullet was aimed and fired to hit the soldier, the soldier would not have realized it until it was first felt. In that case, however, what we call the soldier's conscious being would also cease as with all the physical senses the soldier had right up to the end of his mortal life. An interesting question would be if the soldier's dimension of time would then cease to exist, or would it continue on until it touched or passed through some light or dark cosmic gate first and was properly absorbed?

*If you started to read this little book at this chapter
you can continue on of course,
but you are being told now you will be more than totally lost.*

Let's not look at the things we can see in color. EDL never said anything about cones did he? He just talked about the rods, which would be needed to see things in black and white. EDL also led us to the reeds, shaped like rods, and told us to look to the East.

*So what does looking to the East, the rods, reeds and the
Equator have to do with silhouettes?*

It's not the East we are interested in of course. It's the horizon in the East where the night sky meets the sun when things are not black or white but the many shades of gray to be found. The silhouettes, like the one we find in his shoe, have to do with how we perceive what we see with our gift of sight.

The reeds of course are where he told us to look. So let's now look again at the black and white photograph on the cover of EDL's little book. The one where he looks like a butler standing with a tray ready to serve us with some kind of treat. Look for the triangular white silhouette in his left shoe and the triangular face in the bottom right corner. Why are they there and what does EDL want us to do with them? Let's put them together and see. To put them together you will first need to make a transparency copy of that cover page. You will also notice that the transparency will need to be flipped over so the triangular face will line up properly within the *silhouette* of his left shoe.

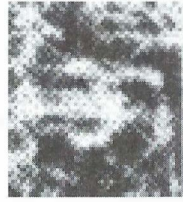
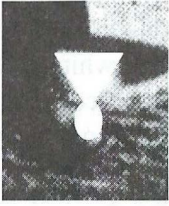

Inserts from - Leedskalnin, Edward: A Book In Every Home, Privately published by Edward Leedskalnin, Homestead, Fl., 1936.

What you get is shown below.

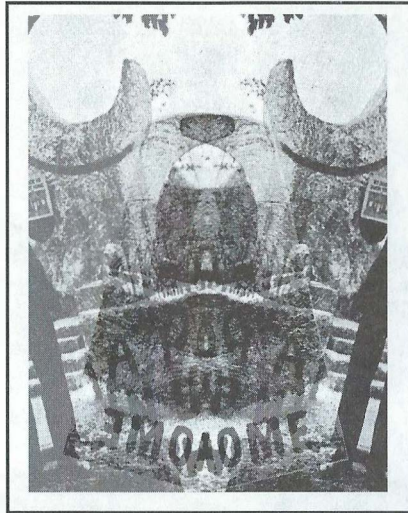

If you look at it closely you will see the face of a bearded man with a gemstone in his head covering that looks like a holy man from the ancient past.

How about the skulls and crossed bones? Do you see them? You probably cannot, since it all has to do with what EDL planned for us to do with that triangular white silhouette in his left shoe and the triangular face in the bottom right corner of that page. If you copied that photograph on a transparent sheet and flipped it over, you would see the bearded mans face but maybe not the crossed bones and the skulls because it's still in black

and white and not gray just yet. To see them you need to make two copies on transparent sheets and look at them on a light table. To see more you would need to make each of these copies less black and white and slightly more gray or approximately twenty-five to twenty-six percent transparent. Then you will see the crossed bones and the skulls and also, a man's figure in the bearded man's face that now looks like a gate. This figure of a man looks like he is walking down a ramp or standing in a shaft of light does he not?

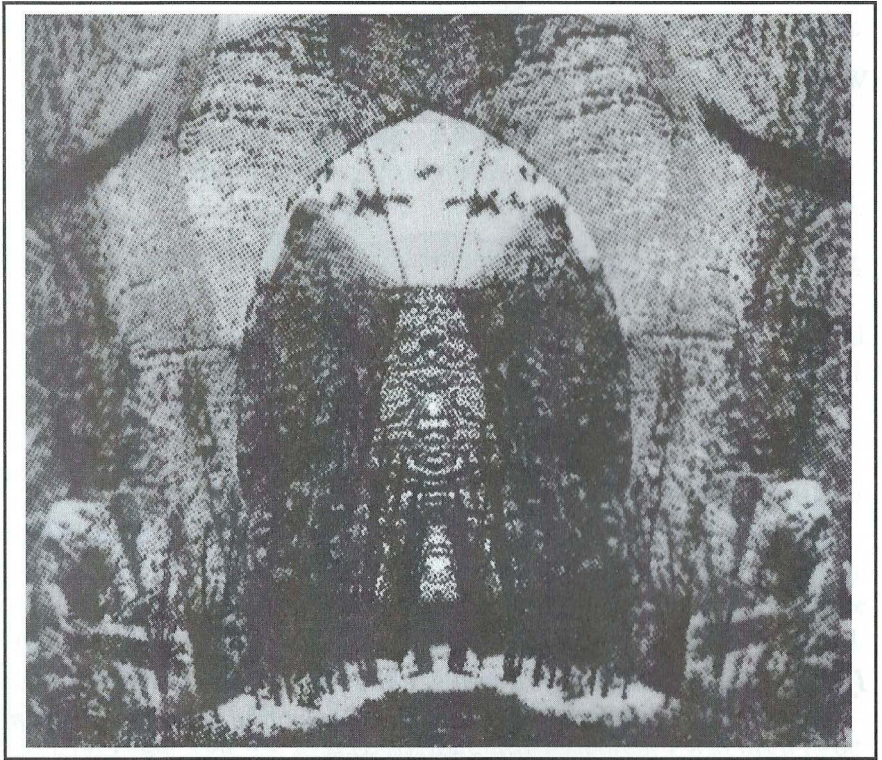

If you look really close at this figure, does it look like it has a helmet with two antenna or are they something else?

In fact all of the pictures in his little book as well as the one on his pamphlet were he is demonstrating his generator, are pictures where you

will find so much more if you line them up just right. They were all carefully made and composed by EDL. As he told us,

you will see how it works.

So why the time, effort and expense by EDL to stage all these pictures so they will show up the path to the things you are looking for? Again it's not polite, but if you answer the following questions it will start to become clear to you. Why does his little book have a blank sheet across from each printed page? Why is it called a book in ever home? Are there some letter keys or descriptive images these pictures hold that could be used to set up an enigma machine, or is there something you can do with light if you turn the pictures right way? You have now been brought to the car you need to drive and you have been shown how to drive at least one model in this little book. It's now up to you to start it and choose the right path to take if you wish to see the unseen, since the magnetic current between the North and South Pole magnets may merely be an analogy of the true cosmic force after all. So is there is a prize for you to find, or is this some elaborate hoax EDL left as his legacy? What do you think? Maybe there is more than just having dominion over gravity that is at stake.

Here is where this little book ends and it is now all up to you. If you want and need a start, rearrange the sixteen letters in the title of his little book for a key phrase.

Here are a few, but of course there are more:

A BOOK IN EVERY HOME
OR KEY ABOVE IN HOME
I B HOOK AN EYE MOVER
HI A KEY BE OVER MOON
AN I OBEY HER MOVE OK
MR HOOK IN EYE ABOVE
I HOME AN KEY B OVER O
EVE HOOK MY ONE RIB A

You will also need the symbols you will find in his pictures that will give you the settings for an enigma machine. Those that are at the end of this chapter are from the picture where EDL is demonstrating his generator, but there are many more on that page. It would be best to concentrate where he led us instead and look for the letters that appear when the cover of his little book overlaps itself like a V.



Once you see what you will find, you will need to select the path you want to take. Its your will; you make the choice if you want to pit not only your wit but also your will against his.

*Remember Dear Reader,
always to keep your mouth shut. If you don't, you might just find yourself like a fish
caught on his double hook instead of the one that tasted the bait and got away.*

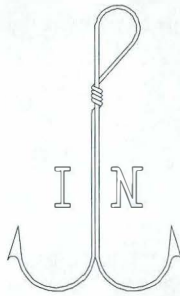
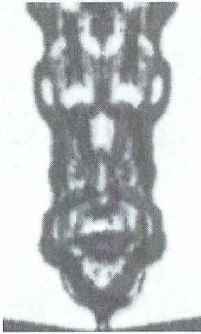

True knowledge can unveil unspeakable power, because the impossible can become just a mere barrier that can be shattered by the truth. Use restraint and practice your knowledge in a humble way. Use it wise and true, because in a twinkle of an eye they may come to you.

THE END
OF THE
BEGINNING

Appendix A -

A-1 Morse Code Page 83

Appendix B -

B-1 First Map Page 84

B-2 Next Map Page 85

B-3 Your First Map Page 86

B-4 Your Next Map Page 87

Appendix C -

C-1 EDL's Hoist Page 88

Appendix D -

D-1 The Greek Alphabet Page 89

D-2 Quasi Greek Messages Page 90

Appendix E -

E-1 Compass Rose Page 91

E-2 Naval Bells Page 92

Appendix F -

F-1 More Pictures Page 93

Appendix G -

G-1 Golden Rectangle Page 98

G-2 Golden Spiral Page 99

G-3 Golden Triangle Page 100

G-4 Golden Spiral Page 101

Appendix H -

H-1 Feb 3, 1946 Page 102

H-2 May 20, 1946 Page 103

H-3 May 20, 1946 Page 104

H-4 Dec 7, 1951 Page 105

H-5 Phase of the Moon Page 106

Morse Code

Alpha	A	.-
Bravo	B	-...
Charlie	C	-. .
Delta	D	-..
Echo	E	.
Foxtrot	F	.. .
Golf	G	--.
Hotel	H
India	I	..
Juliet	J	.---
Kilo*	K	-.-
Lima	L	.-..
Mike	M	--
November	N	-. .
Oscar	O	---
Papa	P	.-. .
Quebec	Q	--.-
Romeo	R	.-. .
Sierra	S	...
Tango	T	-
Uniform	U	..-
Victor	V	...-
Whiskey	W	.-.-
X-ray	X	-. -.
Yankee	Y	-. --
Zulu	Z	--..

Full stop {	.	.-.-
Comma {	,	--..--
Query {	?	..--..
Dash {	-	-....-
Equal or Double Dash {	BT	-.-.-
Fraction Bar {	—	.-.-.
Colon {	:	---...
Semicolon {	;	-.-. .
Right Bracket {	(-.--.
Left Bracket {)	-.--.-
Up Slash {	/	-.-. .
Quote {	"	.-.-. .
Dollar {	\$...-.-.-
Mark {	'	..----.
Paragraph {	NA	.-.-..
Under score {	_	..--.-
Start {	NA	-.-. .
Wait {	NA	.-... .
End of Message {	AR	.-.-. .
End of Contact {	SK	...-.-
Acknowledge {	NA	...-. .
Interrogatory {	NA	..-.-
Emergency Silence {	NA--
Executive Follows {	NA	..-.-.-
Distress Signal {	SOS	...-----
Distress Signal Relay {	NA	-.-.-.-. .

* Invitation to Transmit

1	..----	3--	5	7	9	----.
2	..----	4-	6	-....	8	0	----- { Break-in

First Map

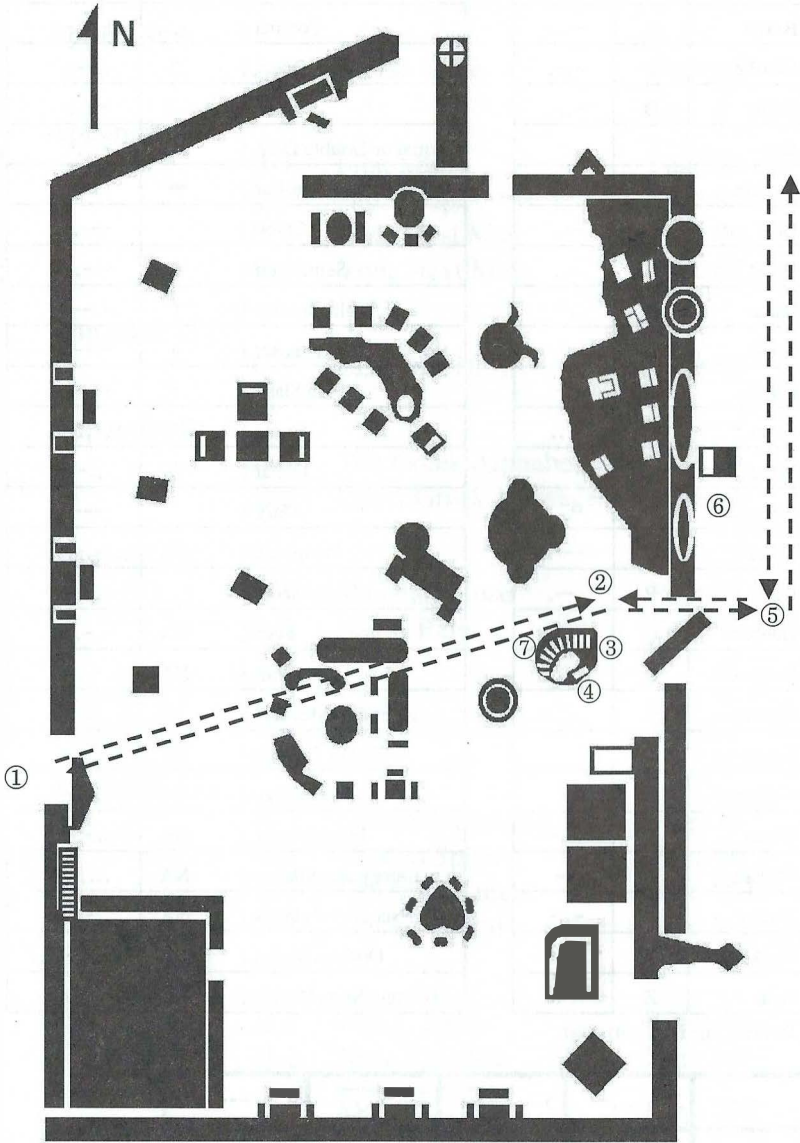

Next Map

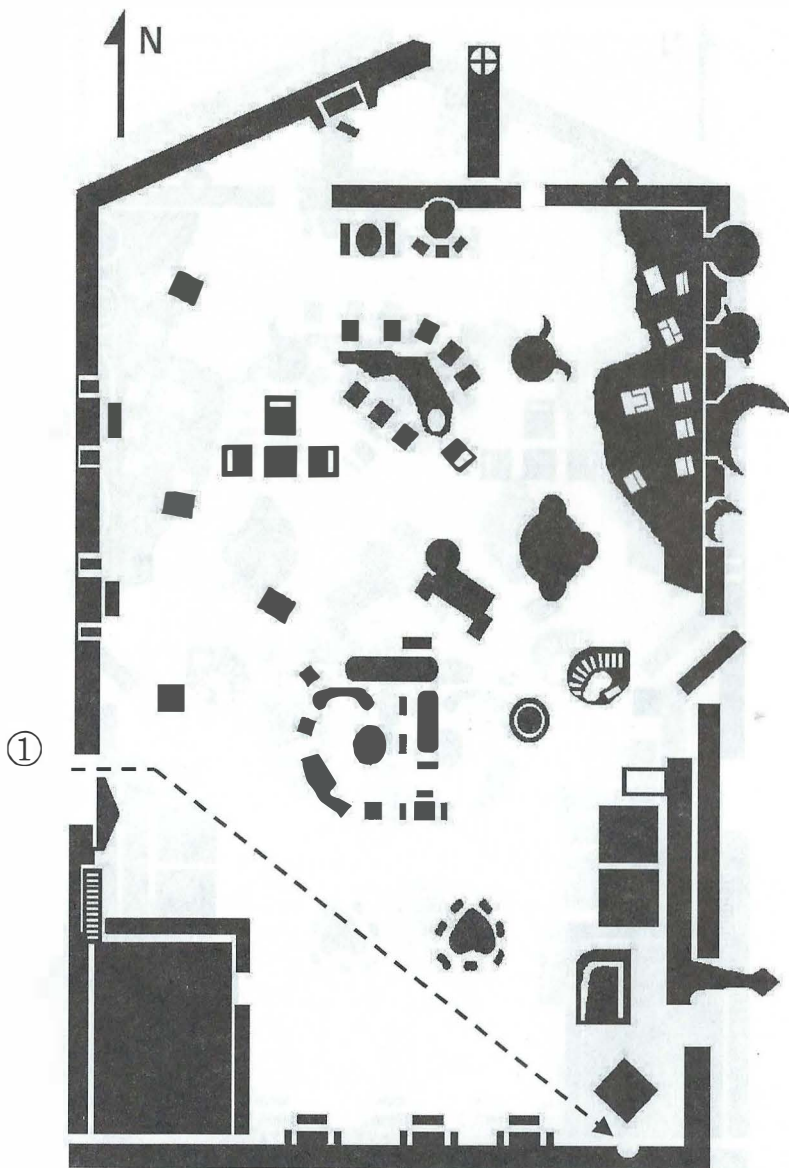

Your Next Map

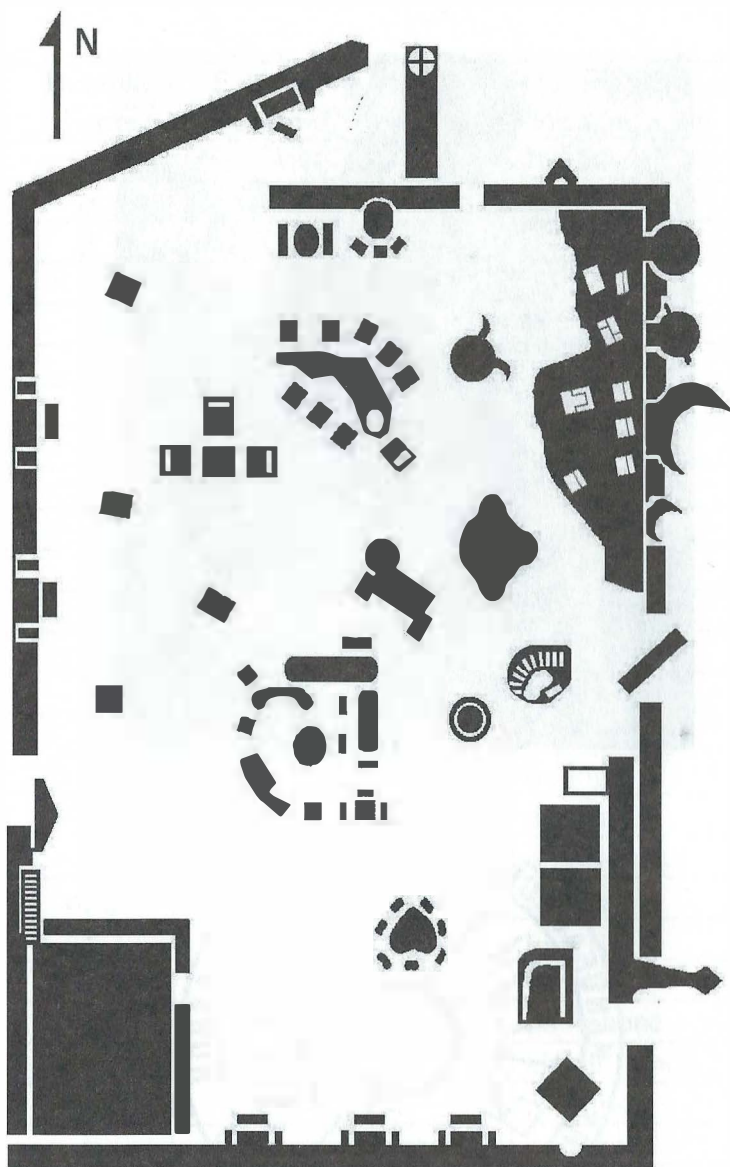

EDL's Hoist

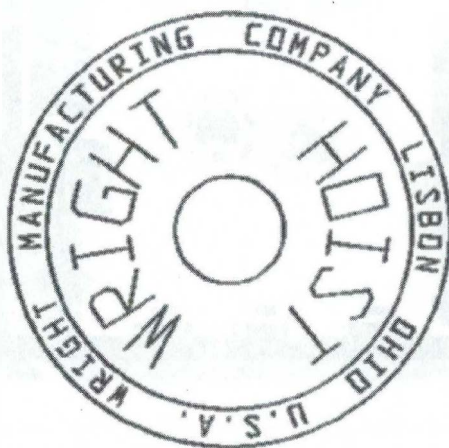
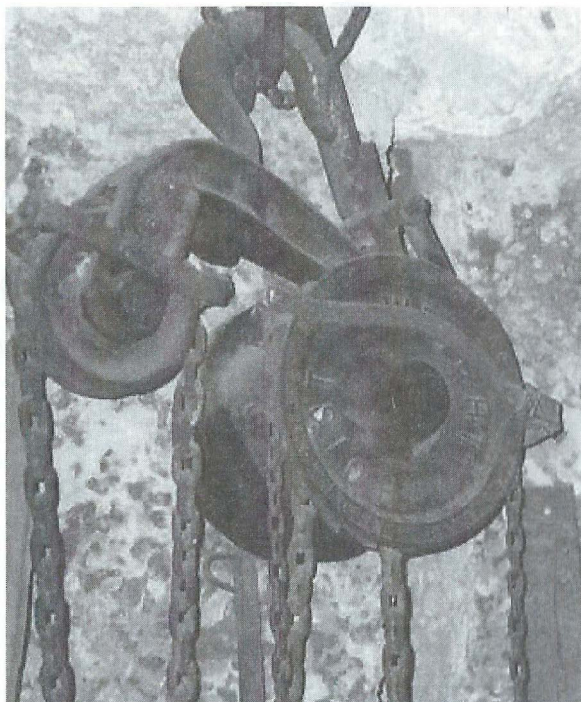

The Greek Alphabet

Humble Form	Elevated Form	English Name	English Pronunciation
α	Α	Alpha	a - father
β	Β	Beta	b - bat
γ	Γ	Gamma	g - gave
δ	Δ	Delta	d - dog
ε	Ε	Epsilon	e - met
ζ	Ζ	Zeta	z, dz - adz
η	Η	Eta	e - they
θ	Θ	Theta	th - thin
ι	Ι	Iota	i - machine
κ	Κ	Kappa	k - king
λ	Λ	Lambda	l - lake
μ	Μ	Mu	m - man
ν	Ν	Nu	n - noon
ξ	Ξ	Xi	x, ks - ax
ο	Ο	Omicron	o - log
π	Π	Pi	p - pea
ρ	Ρ	Rho	r, hro - more
σ, ζ	Σ	Sigma	s - ing
τ	Τ	Tau	t - to
υ	Υ	Upsilon	u - toon
φ	Φ	Phi	ph - phone
χ	Χ	Chi	kh, ch - Bach
ψ	Ψ	Psi	ps - lips
ω	Ω	Omega	o - tone

Quasi Greek Messages

A	Α	father
m	Μ	man
psi	Ψ	lips

W	Ω	o - tone
o	Ο	log
r	Ρ	more
k	Κ	king
s	Σ	sing

Th	thin
i	machine
s	sing
w	o - tone
r	more
i	machine
t	to
i	machine
n	noon
g	gave
i	machine
s	sing
l	lake
i	machine
n	noon
e	met
d	dog

u	toon
p	pea
s	sing
o	log
w	o-tone
h	they
e	met
n	noon
y	toon
o	log
u	toon
r	more
e	they
a	father
d	dog
i	machine
t	to

y	toon
o	log
u	toon
l	lake
o	log
o	log
k	king
e	met
a	father
s	sing
t	to
a	father
n	noon
d	dog
a	father
l	lake
l	lake

Compass Rose

U.S. Navy Blue Jackets Manual

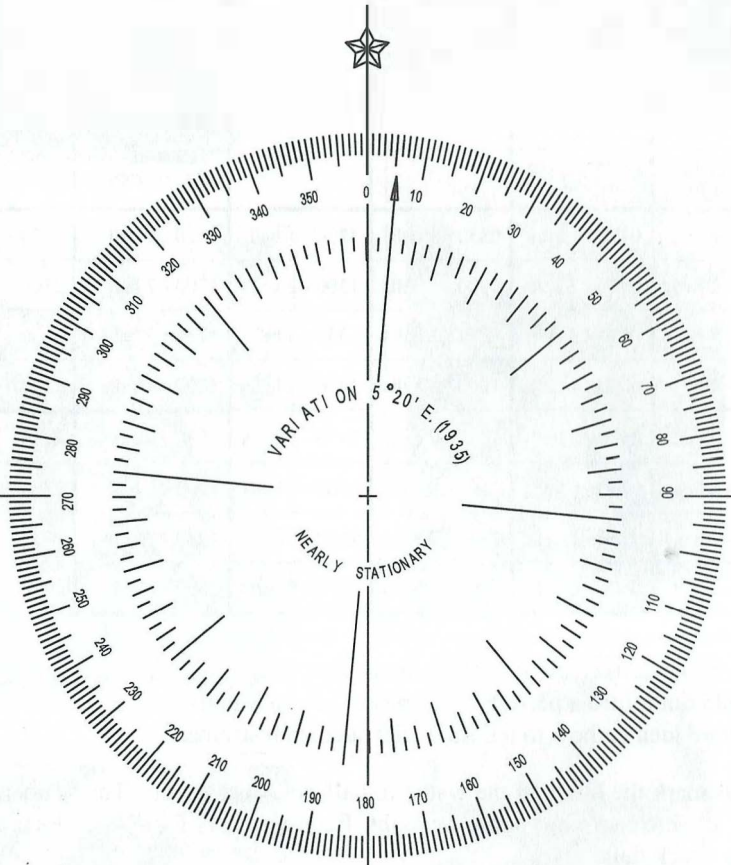

The Naval Bells

Mid Watch Midnight-4AM (0000 - 0400)	Morning Watch 4AM-8AM (0400 - 0800)	Forenoon Watch 8AM-12PM (0830 - 1200)	Afternoon Watch 12PM-4PM (1230 - 1600)	Dog Watch First Dog Watch 4PM-6PM (1600 - 1800) Second Dog Watch 6PM-8PM (1800 - 2000)	Night Watch First Night Watch 8PM-10PM (2000 - 2200) Second Night Watch 10PM-12AM (2200 - 2400)
0030 - 1 bell	0430 - 1 bell	0830 - 1 bell	1230 - 1 bell	1630 - 1 bell	2030 - 1 bell
0100 - 2 bells	0500 - 2 bells	0900 - 2 bells	1300 - 2 bells	1700 - 2 bells	2100 - 2 bells
0130 - 3 bells	0530 - 3 bells	0930 - 3 bells	1330 - 3 bells	1730 - 3 bells	2130 - 3 bells
0200 - 4 bells	0600 - 4 bells	1000 - 4 bells	1400 - 4 bells	1800 - 4 bells	2200 - 4 bells
0230 - 5 bells	0630 - 5 bells	1030 - 5 bells	1430 - 5 bells	1830 - 5 bells	2230 - 5 bells
0300 - 6 bells	0700 - 6 bells	1100 - 6 bells	1500 - 6 bells	1900 - 6 bells	2300 - 6 bells
0330 - 7 bells	0730 - 7 bells	1130 - 7 bells	1530 - 7 bells	1930 - 7 bells	2330 - 7 bells
0400 - 8 bells	0800 - 8 bells	1200 - 8 bells	1600 - 8 bells	2000 - 8 bells	2400 - 8 bells

The use of the bells to mark the time stems from the period when seamen:

- Could not afford a personal time piece (i.e. - a watch)
- Had no idea on how to tell time with such an instrument.

The bells mark the hours of the watch in half-hour increments. The seamen would know if it were morning, noon, or night. Each watch is four hours long and the bells are struck thus:

Note: The end of the watch is at 8 bells, hence the saying "Eight Bells and All Is Well."

A Few Pictures

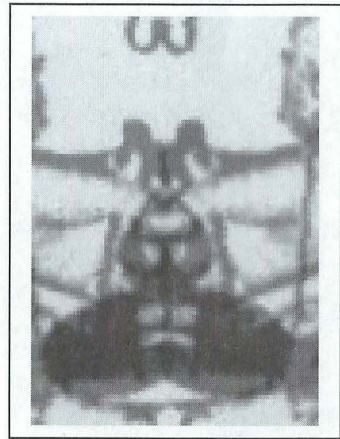
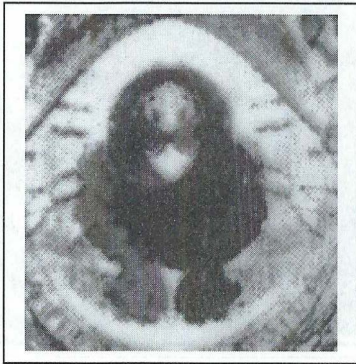
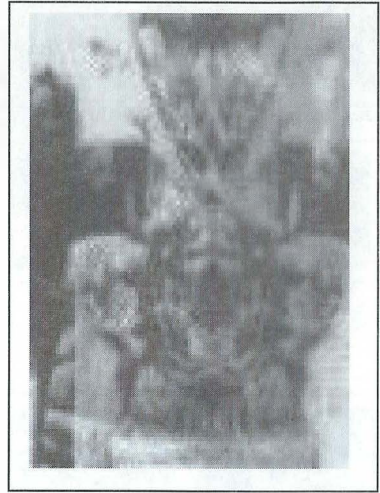
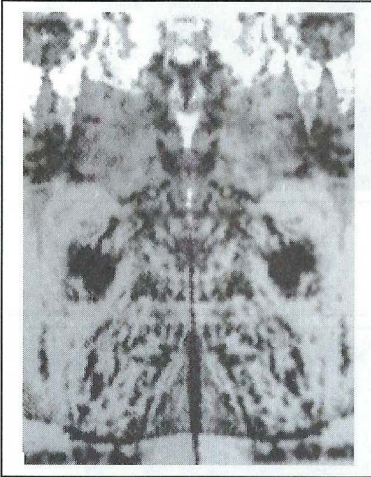
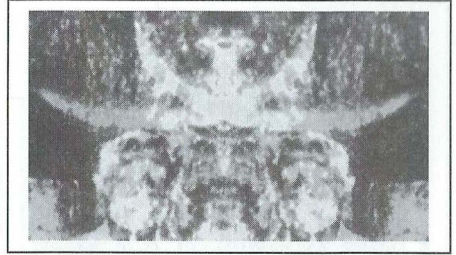
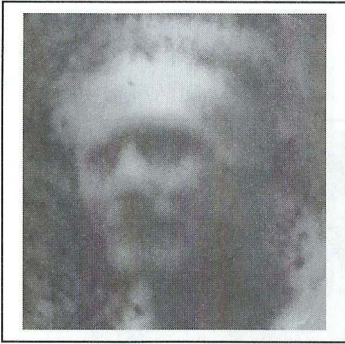

A Few More Pictures

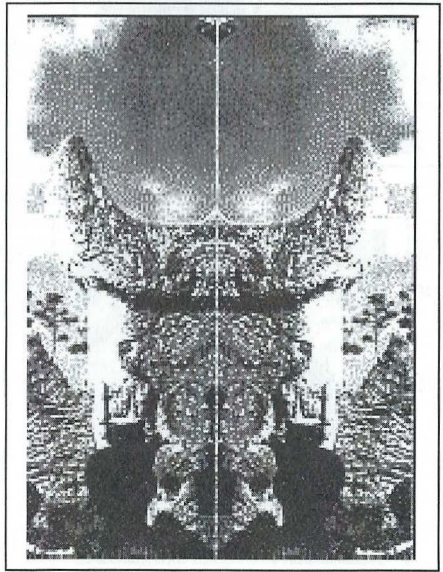
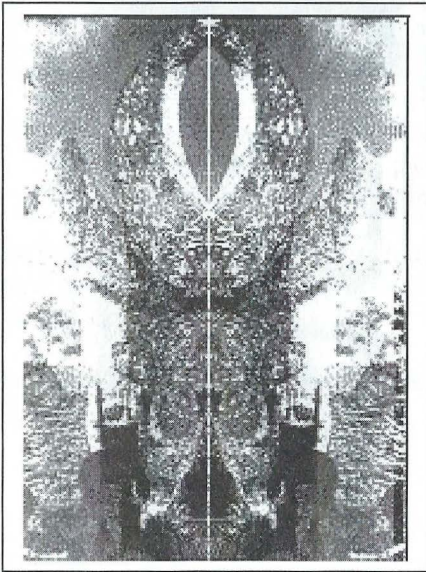
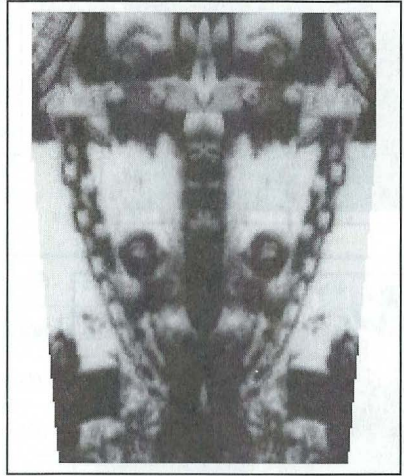
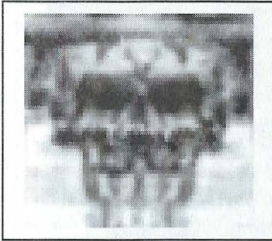
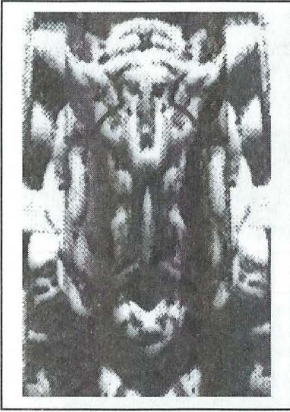

More Pictures

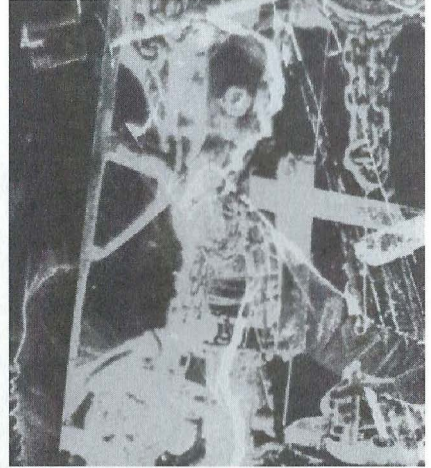
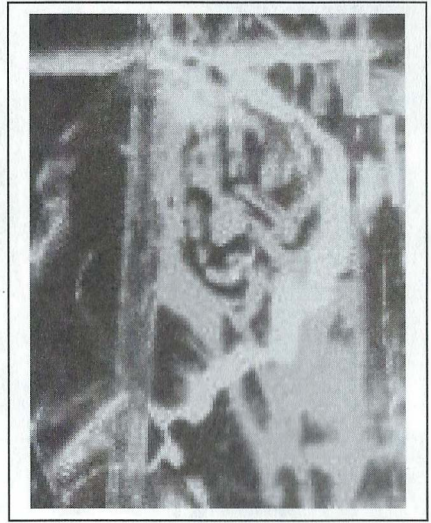

And A Few More Pictures

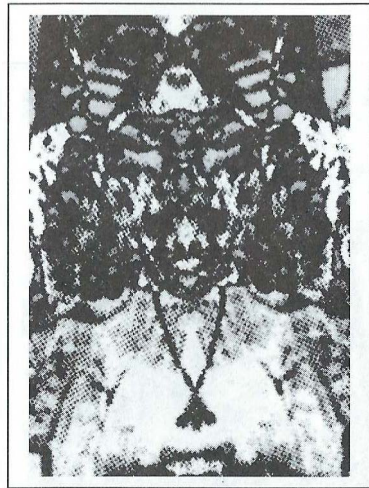
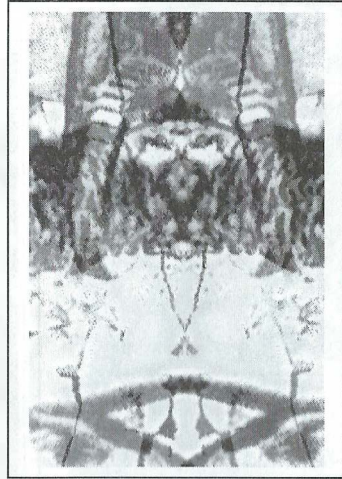
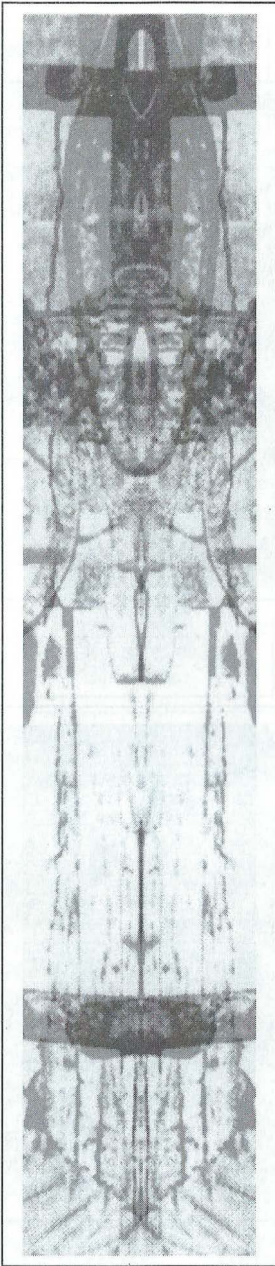

And There Are Hundreds More

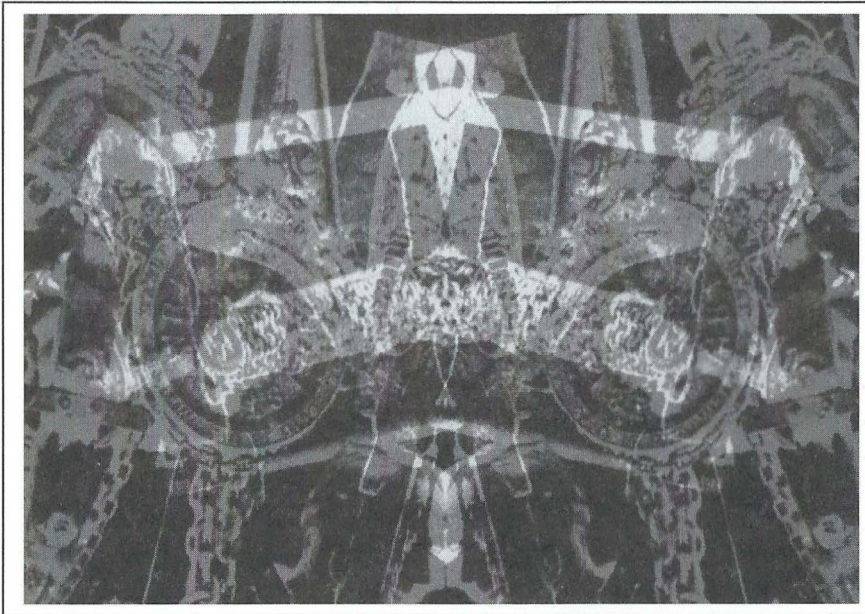
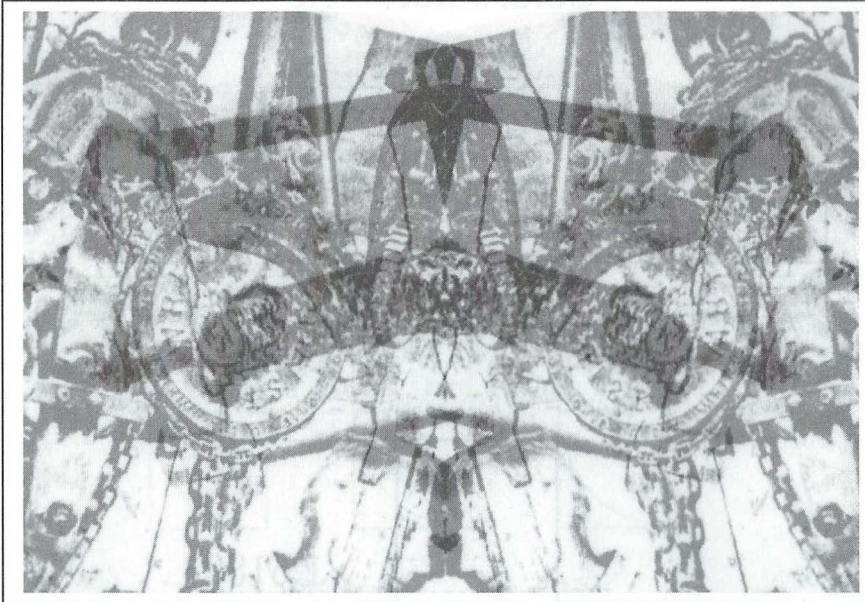

Golden Rectangle

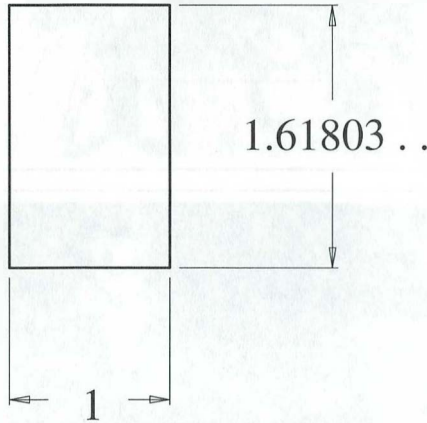
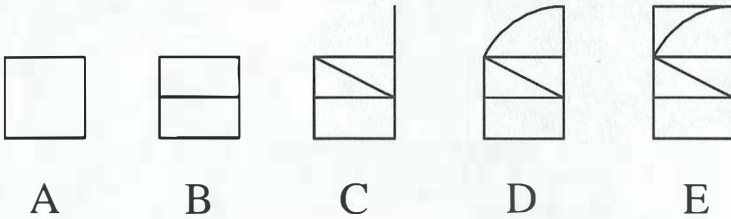

- Draw a square.
- Bisect the square forming two rectangles.
- Extend one side of the square and draw a diagonal across the top rectangle.
- Draw an arc whose radius equals the diagonal to intersect the extended line.
- Complete the Golden Rectangle.

Golden Spiral

(in a Golden Rectangle)

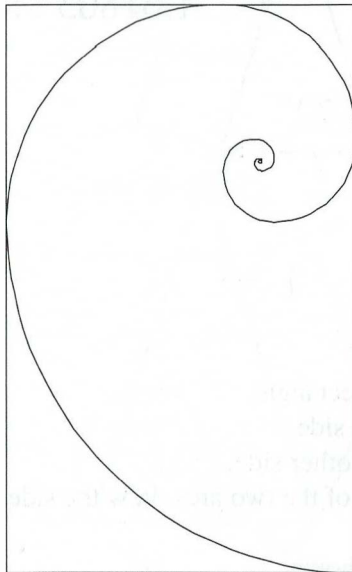
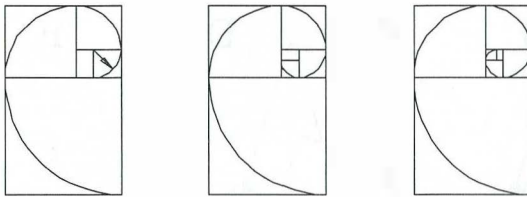
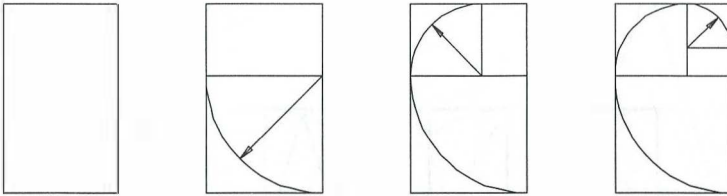

Golden Triangle

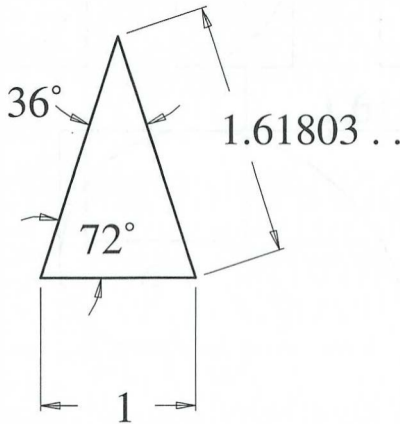
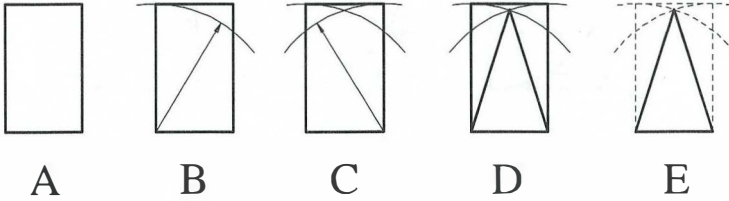

- A. Construct a Golden Rectangle.
- B. Draw an arc from one side.
- C. Draw an arc from the other side.
- D. From the intersection of the two arcs draw the sides of the triangle to the base.
- E. Remove the lines as shown.

Golden Spiral

(about a Golden Triangle)

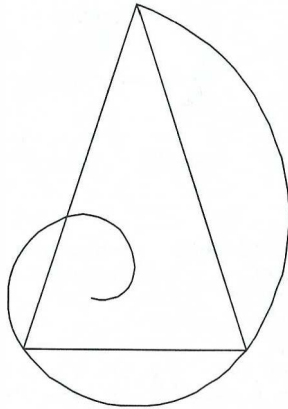
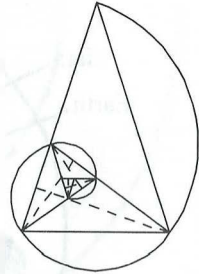
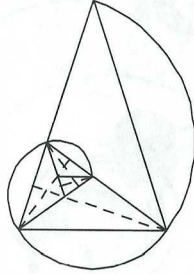
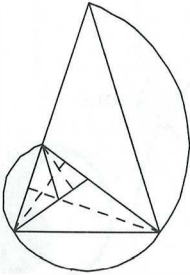
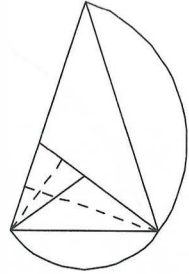
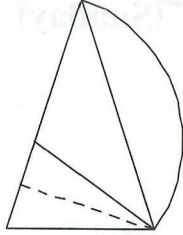
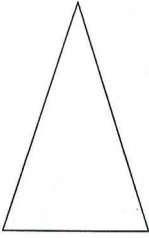

**February 3, 1946
(Sunday)**

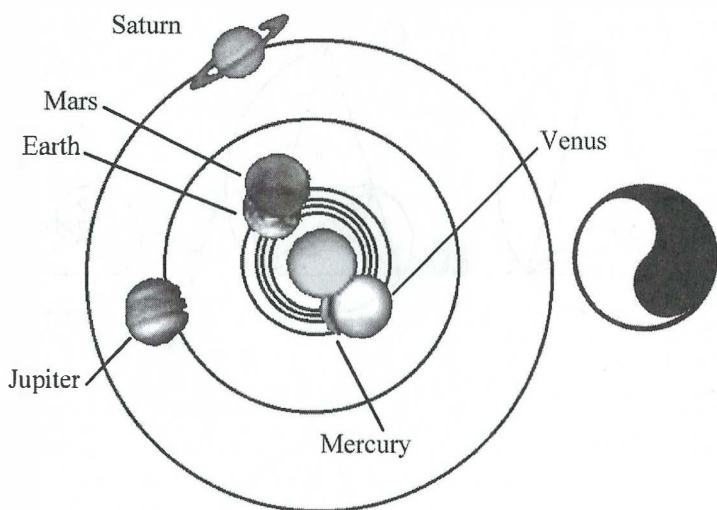

**MAY 20, 1946
(Monday)**

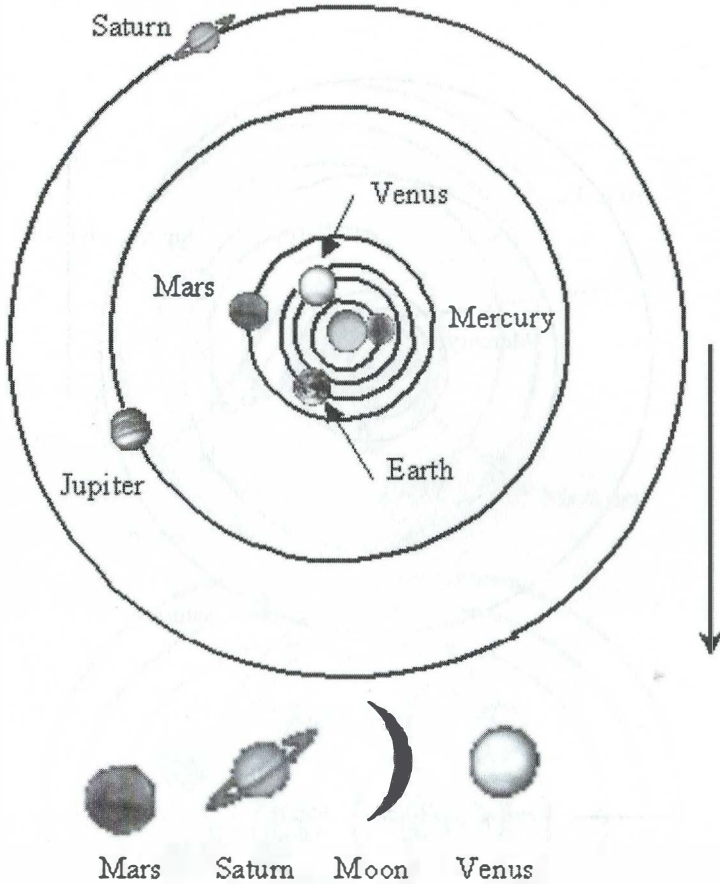

Right	Ascension	Distance Declination	From 25°30'N 80°30'W: (AU)	Altitude	Azimuth	
Sun	3h 44m 29s	+19° 48.2'	1.012	-0.453	112.280	
Setting						
Mercury	2h 52m 40s	+15° 6.2'	1.247	-13.516	114.302	Set
Venus	5h 37m 55s	+24° 35.4'	1.462	25.581	106.427	Up
Moon	18h 46m 38s	-24° 48.0'	62.8 ER	-40.678	-78.297	Set
Mars	9h 3m 55s	+18° 29.8'	1.612	69.710	73.949	Up
Jupiter	13h 10m 16s	-5° 51.4'	4.637	39.311	-57.541	Up
Saturn	7h 31m 12s	+21° 54.9'	9.644	49.954	94.312	Up

**MAY 20, 1946
(Monday)**

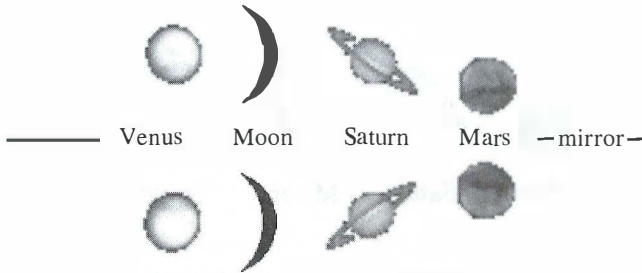
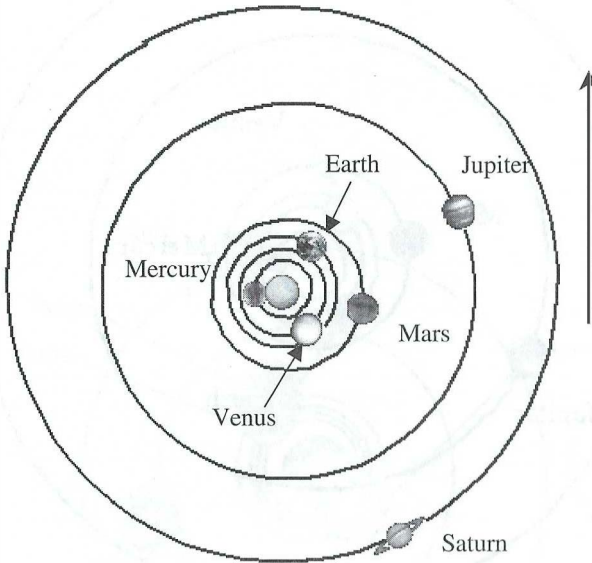

Right	Distance From 25°30'N 80°30'W:				
	Ascension	Declination	(AU)	Altitude	Azimuth
Sun	3h 47m 59s	+19° 59.2'	1.012	38.948	95.820 Up
Mercury	2h 59m 20s	+15° 43.7'	1.258	26.622	95.558 Up
Venus	5h 42m 34s	+24° 39.4'	1.457	65.781	93.804 Up
Moon	19h 33m 5s	-24° 24.9'	62.4 ER	-88.664	144.170 Set
Mars	9h 5m 43s	+18° 21.2'	1.619	66.644	-77.024 Up
Jupiter	13h 10m 2s	-5° 50.2'	4.645	1.889	-82.620 Up
Saturn	7h 31m 33s	+21° 54.2'	9.656	86.377	-7.025 Up

December 7, 1951
(Friday)

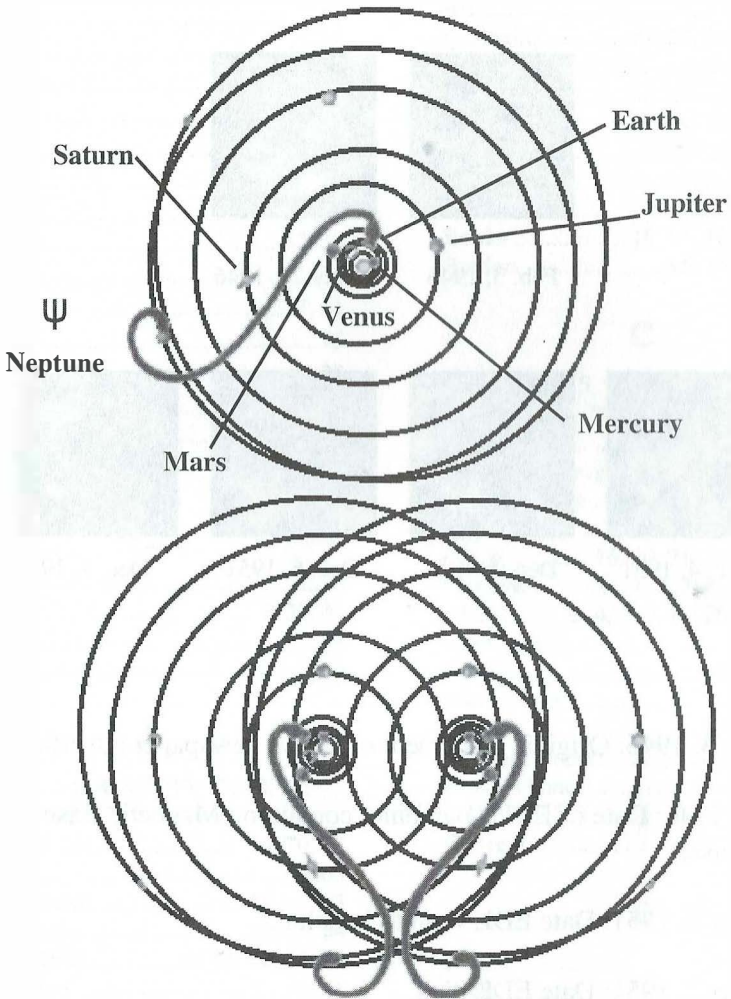

Phase of the Moon



Feb. 3, 1946



May 20, 1946



Dec. 4, 1951



Dec. 5, 1951



Dec. 6, 1951



Dec. 7, 1951

February 3, 1946: Original placement of EDL's newspaper advertisement.

May 20, 1946: Date of EDL's pamphlet containing Magnetic Base & Sound Base.

December 4, 1951: Date EDL went to hospital.

December 7, 1951: Date EDL died.

Index

Symbols

α	61
β	61
Γ	19
θ	19, 60
Ω	19
ω	17, 20, 56
\oint	26
φ	32
Ψ	32, 34
Φ	34
γ	17, 61
∇	75
Δ	9, 35
\cup	39
\circ	33
$\text{\textcircled{X}}$	17

19__

1940	26
1945	8, 39, 44
1946	38
1951	33

A

A	2, 4, 8, 9, 13, 17, 18, 22, 38, 51, 75, 79
Absorbed	69, 70, 75
Adam	64, 65
Advertisement	18, 19, 63
Alpine Map	64
Amp, AMPSI	41, 42, 43, 57
Alan Turing	40, 41
Alphabet	27, 41, 43, 62, 63

B

B	42, 52, 61, 63, 79
Bait	13, 14, 80
Beginning	27, 29, 36, 40, 64, 81
Bible	36
Bioelectric	74
Black	13, 30, 74, 75, 76, 77, 78
Black hole	68
blind	69, 75
Blue cheese	67
Border	16, 17, 19, 20, 49, 67
Borders	16, 17, 34, 49, 50

C

C	5, 9, 18, 27, 32, 41, 42, 45, 47, 52, 55, 56, 57, 63, 70, 71
Camera stand	20, 21
Celestial equator	32, 34
Celestial plane	33
Centerline	32
Circle	16, 20, 21, 26, 47, 61, 68
Clueless	1, 2, 3, 4, 6, 8, 15, 29
Clues	2, 4, 5, 9, 15, 20, 44, 47, 63
Code wheels	41
Cones	69, 73, 74, 76
Coral castle	18, 25, 27, 28
Cosmic	65, 70, 75, 79
Crescent moon(s)	17, 28, 33
Crossed bones	77, 78
C U P R E N T	5, 32
Cur-rent	8

D

D	43, 45, 58
DAE	36, 48, 56
Daemons (demons)	56
Dec 7, 1951	33
DNA	60

Dog (dog watch)62, 63, 64
 Dollar37, 38, 39, 54, 55

E

E3, 6, 9, 12, 32
 E²R.....58
 East 2, 3, 5, 6, 7, 8, 9, 12, 17,
 25, 26, 28, 29, 30, 31, 32, 33, 43, 44,
 46, 55, 64, 73, 76
 EDL's..... 2, 4, 5, 8, 9, 15, 16, 22,
 25, 28, 31, 32, 34, 36, 37, 40, 47, 48,
 49, 50, 51, 53, 58, 60, 61, 65, 76
 Eerie.....20
 Electricity.....6
 Electromagnetic67, 69, 70, 73, 74
 Encoding15, 39, 40, 49, 50, 51, 52
 English27, 30
 Enigma... 39, 40, 41, 42, 43, 44, 45,
 52, 53, 55, 56, 57, 58, 63, 70, 80
 Equator 32, 34, 39, 43, 45, 46,
 52, 54, 55, 56, 61, 62, 64, 73, 75, 76
 ETA36, 48, 56
 Eve.....64, 79
 Eye.....8, 38, 67, 73, 74, 79, 80
 Ez20, 44

F

F57
 Fallen angels56, 60
 Father.....17, 58
 Feb 3, 1946.....33
 First machine30, 32, 52, 55
 Fishing.....13, 48, 53
 Float.....72
 Four..... 11, 17, 18, 25, 26, 27, 28,
 35, 36, 37, 39, 40, 47, 52, 55, 58, 62,
 63
 Four sided gate52, 27
 Friction72
 Frozen25

G

g 18, 68, 69
 G 3, 8, 41, 45, 52, 53
 Gamma 61
 Gamma rays..... 70
 Gate.... 1, 4, 12, 25, 26, 27, 28, 29, 30,
 33, 36, 46, 47, 48, 52, 55, 64, 75, 78
 Gate, 3-ton..... 27, 31
 Gate, 9-ton..... 27, 29, 33
 Gem 53, 65
 Gemini..... 22
 Geo-magnetic 31
 Geometry 17, 34, 35, 49
 Get a 26, 36, 39, 40, 46, 57, 58, 73
 GETA .36, 42, 43, 45, 46, 52, 56, 63, 64
 GIGO..... 42
 God..... 36, 47, 64
 Golden rectangle 34, 49, 50
 Golden Triangle 50
 Gravity 60, 69, 72, 73, 79
 Gravity bottle 68, 69
 Gravity field 34, 72
 Gray..... 74, 75, 76, 78
 Greek..... 19
 Greek gods 23, 60
 Greek mathematicians 34
 Greek symbol 17, 19, 61
 Grundstellung..... 41, 53

H

H 52, 61
 Half 29, 38, 47, 54, 71, 73
 Heaven 31, 48, 56, 64
 Heavy 11, 14, 22
 Hell..... 56
 Holy..... 57, 58, 60, 61, 62, 77
 Hook..... 14, 48, 64, 79, 80
 Horizon 73, 76
 Hugs and kisses..... 44
 Hug you..... 54

- I**
- I 3, 4, 5, 6, 7, 9, 12,
17, 22, 39, 41, 45, 46, 60, 64, 79
- Inertia 72
- Infinite 22
- Infinite frequency 70
- Infinite mass 66, 67
- Infinite number 32, 68
- Infinite size 66
- Infinite universe 68
- Infinite vacuum 70, 71,
- Infinity 29
- Iota 56
- J**
- J 22, 27, 42, 43, 44,
45, 54, 55, 57, 63, 64
- Joke 46, 48, 54, 55
- K**
- Key(s) 12, 15, 20, 46, 56, 79
- L**
- L 9, 11, 12, 13, 14, 18, 27, 44, 55
- Latin 22
- Latvian 27, 62
- Life 32, 35, 36, 56, 60, 75
- Light 28, 30, 34, 45, 61, 63, 65, 66,
67, 68, 69, 70, 71, 73, 74, 75, 78, 79
- Light beam 66, 67, 68
- Light table 17, 78
- Lips 57, 58, 60, 61
- Little book, EDL's 76
- Little book, His 19, 20, 21, 22,
23, 34, 51, 58, 59, 61, 78, 79, 80
- Little book, This 19, 20, 21,
23, 25, 27, 33, 36, 44, 46, 47, 48, 49,
50, 58, 62, 76, 79
- Loan 46, 47, 53, 54
- M**
- M 17, 34, 58
- Magnetic base 18, 19, 22
- MAGNETICCUPRENT 5, 9, 32, 35
- Magnetic current 2, 5, 9, 17, 18,
30, 37, 79
- Magnetic current booklet 2, 4, 5,
9, 12, 15, 16, 17, 18, 19, 27, 32, 37,
39, 40, 42, 43, 45, 46, 47, 49, 52, 54,
55, 58, 59, 62, 63, 64, 65, 66, 69
- Magnetic energy 71
- Magnetic field 71
- Magnet(s) 9, 38, 61, 72, 73
- Map 25, 28, 29, 64
- Map, Alpine 64
- Map, Treasure 48
- Mars 26, 32, 33, 34, 47, 63
- Math 17
- Mathematical 20, 22, 55
- May 20, 1946 38
- mc^2 18
- Michelangelo 60
- Mineral, vegetable and animal life...
16, 17, 18, 49, 59
- Mirror(s) ..12, 28, 29, 30, 33, 35, 51, 52,
55, 58, 59, 60, 61, 67, 68
- Moon(s) ...17, 26, 27, 28, 33, 34, 47, 63,
79
- Moon fountain 28, 59
- Morse code 12, 40
- mortal 75
- mortality 36
- N**
- N 54
- Not, Not or reversed 13, 38
- North 2, 3, 25, 26, 28, 29, 31, 32, 62, 79
- Novus 39

Number 22, 32, 35,
40, 41, 42, 44, 47, 62, 63, 68

O

O9, 21, 43, 57, 59, 60, 79
Oh3, 17, 20, 21, 22, 23
O-tone30

P

P5, 8
Page 196, 7, 19, 20, 43, 44
Photon67
Planet(s)26, 29, 32, 34, 60, 62
Polaris telescope *see telescope*
Pole(s)25, 31, 62, 75, 79
Polish40, 41
Power58, 60, 80
Procreate60
PRTNT32, 41, 42, 45
Pyramid9, 35, 38, 39, 44

Q

Quasi greek27, 30, 57, 62

R

r7, 18, 36
R5, 8, 12, 34, 41, 43, 51, 58
Radio70, 73
Radioactive61
Reed(s)58, 59, 61, 76
Reflect(s)29, 68
Reflecting68
Reflection .29, 30, 33, 58, 61, 62, 67, 68
Reflective17, 28, 68
Reflector40, 42, 53
Religion, religious15, 48
Repel73
Retina69, 73, 74

Reverse 12, 17, 26, 27, 28,
29, 31, 33, 40, 53, 57, 69, 74, 75
Ring(s) 4, 5, 14, 25, 28, 33,
34, 40, 42, 45, 47, 52, 53, 54, 55
Ringstellung41, 58
Rivet59, 60
Rock 29, 36, 42, 43, 45,
46, 48, 52, 56, 63, 64, 72, 73
Rock Gate Park4, 12, 22, 25, 28, 64
Rocket(s)31, 34, 49, 60, 72
Rod9, 38, 43, 44, 45, 63, 69, 73, 76
Roswell59
Rotating 1, 25, 26,
27, 28, 29, 30, 47, 52, 64
Round gate26

S

S26, 27, 47, 50, 61, 73
Sacred [Number] Nine35, 44
Saturn26, 32, 33, 47, 60, 63
Science 15, 22, 39, 45, 66, 69, 70, 71, 72
Scriptures70
Sex(ual)15, 54, 60
Shoe59, 76, 77
Sight25, 28, 69, 70, 73, 75, 76
Sign4, 11, 13, 14, 17
Silhouettes73, 76
Sixteen18, 79
Skulls77, 78
Sound12, 66, 70, 75
Sound base18, 19, 22
South2, 26, 28, 29, 31, 62, 79
Southern cross23
Sphere29, 31, 68
Spiral26
Spying eyes8
Staples55, 56
Steckerbrett40, 64, 65
Sumerian60
Sun, sunlight17, 28, 29, 63, 76
sundial22, 25, 47

T

- Telescope 26, 28, 32, 33
 The End 8, 13, 18, 22, 27, 35,
 45, 54, 63, 75, 80, 81
 Thin machine 27, 28, 29, 30, 34,
 36, 46, 52, 55, 58, 59, 61
 Three sided gate 27, 52, 55
 Throne 26, 27
 Time 4, 15, 16, 17, 22, 23,
 25, 27, 28, 30, 32, 33, 34, 35, 36, 37,
 40, 43, 53, 60, 62, 64, 68, 72, 75, 79
 Transverse wave 71
 Treasure map 48
 Triangular face 59, 76, 77

U

- u 26
 U 3, 5, 9, 19, 32, 38,
 41, 44, 52, 57, 61, 64, 65
 U. S. A. 23, 34, 35, 50, 58, 61
 UFO 44, 48, 59
 Umkehrwalze 40, 41, 42, 43, 44,
 45, 46, 52, 53

V

- V 17, 18, 51, 80
 Vegetable soup 10
 Velocity 70, 71, 73

W

- W 20, 41, 44, 45, 47, 52
 wall 7, 25, 26, 27, 28, 29,
 30, 32, 33, 47, 73, 74
 Walzenlage 41, 52
 Waning Gibbous 33
 War 13, 36
 War, god of 47
 War-Wit 47
 Weightless 72, 73
 West gate 25, 27, 28, 64
 Whatever-it-is 67, 68, 69, 70, 71
 Whatever-it-was 68
 White 13, 59, 74, 75, 76, 77, 78
 Wire 19, 22, 61
 World War II 39, 40
 Works 17, 25, 26, 27, 29,
 35, 36, 37, 38, 42, 44, 45, 47, 48, 52,
 62, 64, 72, 79
 Worm 46, 47, 48, 53, 54, 65

X

- X 17, 23, 27, 45
 X-rays 70

Y

- You 16, 20, 21, 22, 26,
 28, 29, 30, 33, 34, 35, 39, 40, 44, 45,
 48, 49, 58, 60, 64, 66, 67, 72, 76, 77,
 79, 80

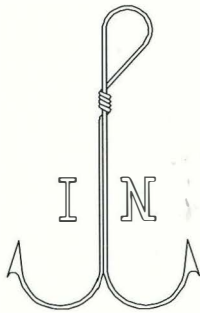

**Passels
Information
Network**
SM

www.passels.com

ISBN 0-9701202-0-6



9 780970 120205

52800

